

# BR - BOOSTER RELAY

## INSTRUCTION MANUAL 2074

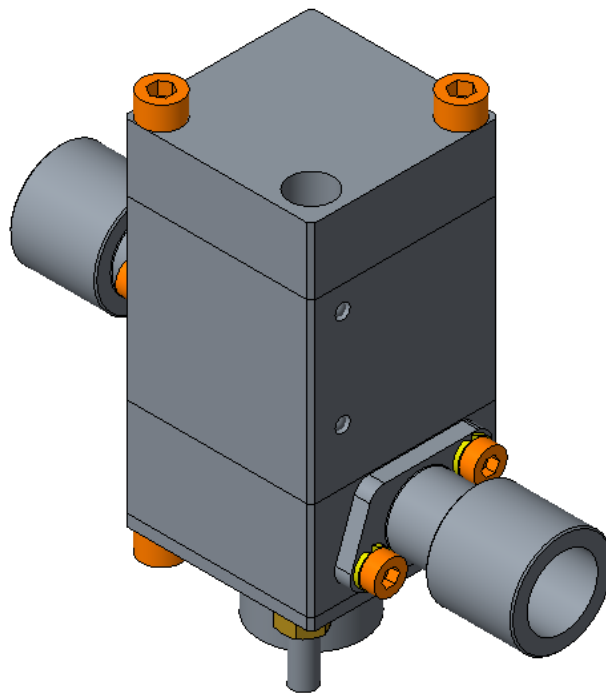

  
*Engineering  
GREAT Solutions*

01/02/2019	00	Issue	I. Zucchi	F. Tondolo
Date	Revision	Description	Compiled	Approved

*STI S.r.l. has taken every care in collecting and verifying the documentation contained in this Instruction Manual. The information herein contained are reserved property of STI S.r.l.*

## INDEX

<b>1</b>	<b>GENERAL INFORMATION .....</b>	<b>1</b>
1.1	GENERAL WARNINGS.....	1
1.2	GENERALITIES.....	1
1.3	MANUFACTURER.....	1
1.4	TERMS AND CONDITIONS .....	1
1.5	MANUFACTURER'S LIABILITY .....	1
1.6	APPLICABLE STANDARDS AND DIRECTIVES .....	2
1.7	SYMBOLGY USED .....	2
<b>2</b>	<b>DEVICE DESCRIPTION .....</b>	<b>3</b>
2.1	GENERAL DESCRIPTION.....	3
2.2	BOOSTER CODING DESCRIPTION.....	4
<b>3</b>	<b>TECHNICAL DATA.....</b>	<b>5</b>
<b>4</b>	<b>LABEL.....</b>	<b>6</b>
<b>5</b>	<b>INSTALLATION .....</b>	<b>7</b>
5.1	TRANSPORT .....	7
5.2	RECEPTION.....	7
5.3	STORAGE.....	7
5.4	REQUIREMENTS OF STABILITY .....	7
5.5	DOCUMENTS AND DIMENSIONAL DRAWINGS .....	7
5.6	INSTALLATION.....	8
5.7	DISASSEMBLING .....	12
<b>6</b>	<b>OPERATION AND USE.....</b>	<b>13</b>
6.1	OPERATION DESCRIPTION .....	13
6.2	INTENDED USE.....	20
6.3	REASONABLY FORESEEABLE MISUSE .....	20
6.4	OPERATING LIMITS.....	20
6.5	RESIDUAL RISKS .....	21
<b>7</b>	<b>INSTRUCTIONS FOR THE OPERATOR .....</b>	<b>21</b>
<b>8</b>	<b>MAINTENANCE.....</b>	<b>22</b>
8.1	PERIODIC INSPECTIONS .....	22
8.2	SPECIAL MAINTENANCE .....	22
8.3	REPAIRS .....	22
8.4	REASSEMBLING .....	22
8.5	MECHANISM LUBRICATION.....	22
<b>9</b>	<b>PARTS LIST GENERAL ASSEMBLY.....</b>	<b>23</b>
9.1	BR ASSEMBLY – BR-08SSH00 / BR-08SSS00 / BR-08SSL00.....	23
9.2	BR ASSEMBLY – BR-08SSH01 / BR-08SSS01 / BR-08SSL01.....	24
<b>10</b>	<b>TROUBLESHOOTING .....</b>	<b>25</b>
<b>11</b>	<b>SPARE PARTS .....</b>	<b>25</b>
<b>12</b>	<b>DECOMMISSIONING.....</b>	<b>26</b>



# 1 GENERAL INFORMATION

## 1.1 General Warnings

<b>Important</b> 	<b>This Instruction Manual is an integral part of the machine, it should be carefully read before carrying out any operation and it should be kept for future references. The operators shall adopt the safety precautions required by the country where the product is installed. This Instruction Manual is realized in accordance with the Directive 2006/42/CE.</b>
---	---

## 1.2 Generalities

STI S.r.l. accessories are conceived, manufactured and controlled according to the Quality Control System in compliance with EN ISO 9001 International Standard.

## 1.3 Manufacturer

With respect to Machinery Directive 2006/42/EC, the Manufacturer of the described BR Booster is STI S.r.l. as specified on the label.

STI S.r.l. Via Dei Caravaggi 15  
24040 Levate (BG) Italy  
Tel. +39 035 2928.2  
Fax +39 035 2928.247  
[imisti.sales@imi-critical.com](mailto:imisti.sales@imi-critical.com)

## 1.4 Terms and conditions

STI S.r.l. guarantees each single product to be free from defects and to conform to current goods specifications. The warranty period is one year from the date of installation by the first user, or eighteen months from the date of shipment to the first user, whichever occurs first.

The warranty does not cover special products or components not covered by warranty in their turn by subcontractors. No warranty is given for products which have been subject to improper storage, improper installation, misuse, corrosion, or which have been modified or repaired by unauthorised personnel: it is not advisable that customer or end users modify the device characteristics.

## 1.5 Manufacturer's Liability

STI S.r.l. declines all liability in the event of:

- use of the BR in contravention of local safety at work legislation;
- incorrect installation, disregard or incorrect application of the instructions provided on the BR label and in this manual;
- modifications without STI's authorisation;
- work done on the unit by unqualified or unsuitable persons.

## 1.6 Applicable Standards and Directives

- EN ISO 12100:2010 Safety of machinery - General principles for design;
- 2006/42/EC Machinery Directive;
- 2014/68/UE Pressure Equipment Directive (PED);

## 1.7 Symbology Used

### 1.7.1 Signs of warning

Be careful where these symbols are shown, they indicate a potentially hazardous situation and they warn that if the steps are not properly performed, **MAY RESULT CAUSING** serious injury, death or long-term risks to the health of exposed persons.



GENERAL DANGER



DANGER POWER SUPPLY



CRUSHING HAZARD

### 1.7.2 Signs of obligation



General obligation (with the possible supplementary signboard)



Obligation to wear protective clothing.



Obligation to wear protective footwear.



Obligation to wear a helmet.



Obligation to protect your eyes.



Obligation to protect your hearing.

## 2 DEVICE DESCRIPTION

### 2.1 General Description

The Booster Relay BR is a flow amplifier that allows to increase the actuator stroking time by increasing the fluid mass flow to the actuator or from the actuator. Designed to meet high control applications, the BR booster contains an integral stabilizing bypass valve controlled by a screwdriver adjustment. The bypass valve screwdriver creates a pressure drop between the pilot and the actuator connection depending on its adjustment and the working fluid flow rate.

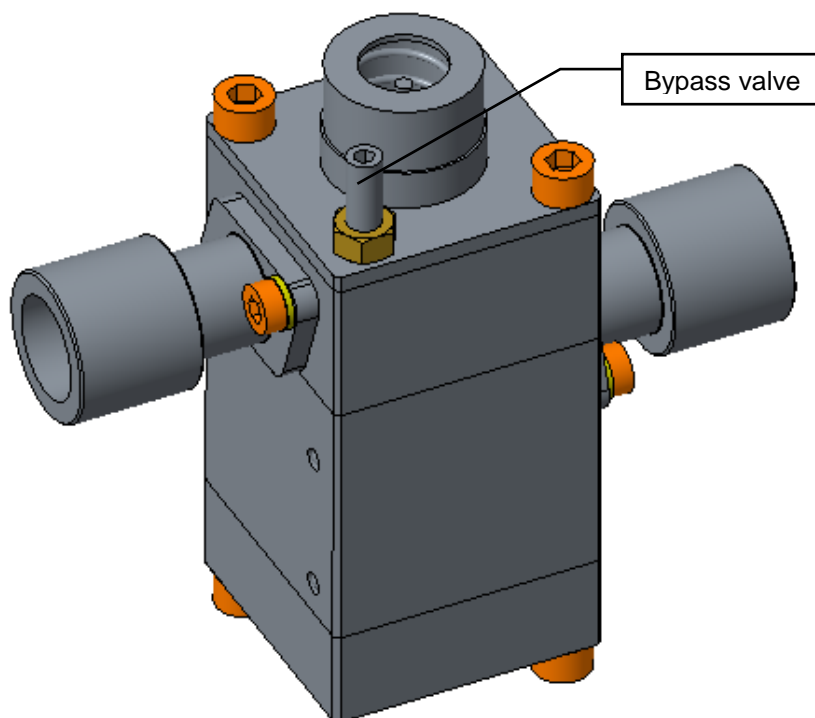
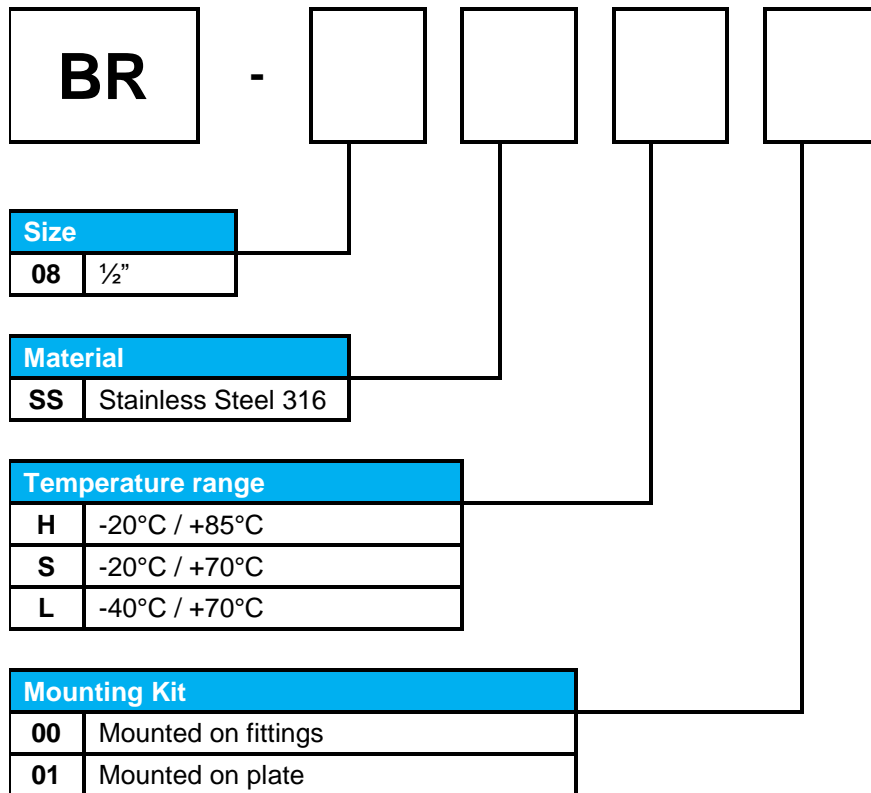

Figure 1 – Booster Relay BR

## 2.2 Booster Coding Description





### 3 TECHNICAL DATA

	Technical features (*)		
BR Model	BR-08SSH	BR-08SSS	BR-08SSL
Body Material	Stainless steel 316	Stainless steel 316	Stainless steel 316
Booster Size	1/2"	1/2"	1/2"
Media	Instrument air Natural gas	Instrument air Natural gas	Instrument air Natural gas
Supply connection (S)	1/2" NPT Female	1/2" NPT Female	1/2" NPT Female
User connection (U)	1/2" NPT Female	1/2" NPT Female	1/2" NPT Female
Exhaust connection (E)	3/4" NPT Male	3/4" NPT Male	3/4" NPT Male
Pilot/Signal connection (P)	1/4" NPT Female	1/4" NPT Female	1/4" NPT Female
Cv max @6 bar (S→U)	3,80	3,80	3,80
Cv max @6 bar (U→E)	4	4	4
Testing temperature range	-20/+85 °C	-20/+70 °C	-40/+70 °C
Operating pressure range	3 bar / 7 bar	3 bar / 7 bar	3 bar / 7 bar
Max supply pressure	10,4 bar	10,4 bar	10,4 bar
Pressure containment	Up to 15 bar	Up to 15 bar	Up to 15 bar
Expected lifetime @20°C	100000 cycles	100000 cycles	100000 cycles

(\*) All the models are PED 2014/68/UE and ATEX 2014/34/UE (see label for ATEX details) certified.

## 4 LABEL

The label attached on the BR contains the info related to ATEX certification. This label must be attached on the booster when the BR is sold alone. When the BR is sold mounted on the actuator or as spare part, the label is not required.

It is forbidden to modify the information and the marks without previous written authorization by STI S.r.l.





	Via Dei Caravaggi 15 – 24040 Levate (Bg)–ITALY www.imi-critical.com – FAX +39 035 2928247		
MODEL	<input type="checkbox"/> BV	<input type="checkbox"/> BW	<input type="checkbox"/> BR
	<input type="checkbox"/> h IIC T6 Gb	h IIIC T85°C Db	
	<input type="checkbox"/> h IIC T5 Gb	h IIIC T100°C Db	
Deposit.file ref.			

Figure 2 – Booster Relay label

## 5 INSTALLATION

Important		<b>Not performing the following procedures will invalidate the product guarantee.</b>
-----------	---	---

### 5.1 Transport

Important		<b>The lifting and handling should be made by qualified staff and in compliance with the laws and provisions in force.</b>
-----------	---	--

### 5.2 Reception

- Check that the model corresponds with that of order confirmation.
- Check that the BR was not damaged during transportation.

### 5.3 Storage

Booster Relay BR leaves the factory in perfect conditions. Performances of each unit are guaranteed by tests and data reported on the specific. To maintain these conditions until the BR is installed on site, proper attention must be observed for preservation during the storage period.

If the BR needs storage, before installation follow these steps:

- place it on a wood surface pallet or on metallic support, thus it is not in direct contact with the ground, and packed with appropriate covering;
- make sure that plastic plugs are present on the pneumatic connections;
- keep the BR protected from direct weather conditions;
- if stored outdoor, replace plastic plugs on pneumatic connections with metal plugs that guarantee perfect tightness.

### 5.4 Requirements of Stability

Concerning the requirement of stability during installation and disassembling, it is possible to refer to the next chapters 5.6 and 5.7.

### 5.5 Documents and dimensional drawings

Pneumatic diagrams, wiring diagrams and dimensional drawings are furnished with document accompanying the actuator.

## 5.6 Installation

<p><b>Warning</b></p> 	<p><b>Before proceeding with any Installation, the following instructions must be respected:</b></p> <ul style="list-style-type: none"><li>- Always wear protective clothing, gloves, and eyewear to prevent personal injury;</li><li>- Check with your process or safety engineer for any additional measures that must be taken to protect against process media.</li></ul>
---	---

### **5.6.1 Checks to be performed before installation**

- Check that the coupling dimensions meet the specified coupling dimensions.
- Prepare the necessary tools for the assembly and setting of the unit.
- Check that the outer surface of the BR is free from dust and dirt.
- Clean the BR surfaces and remove anything that might prevent a correct installation.

### 5.6.2 BR mounting on actuator

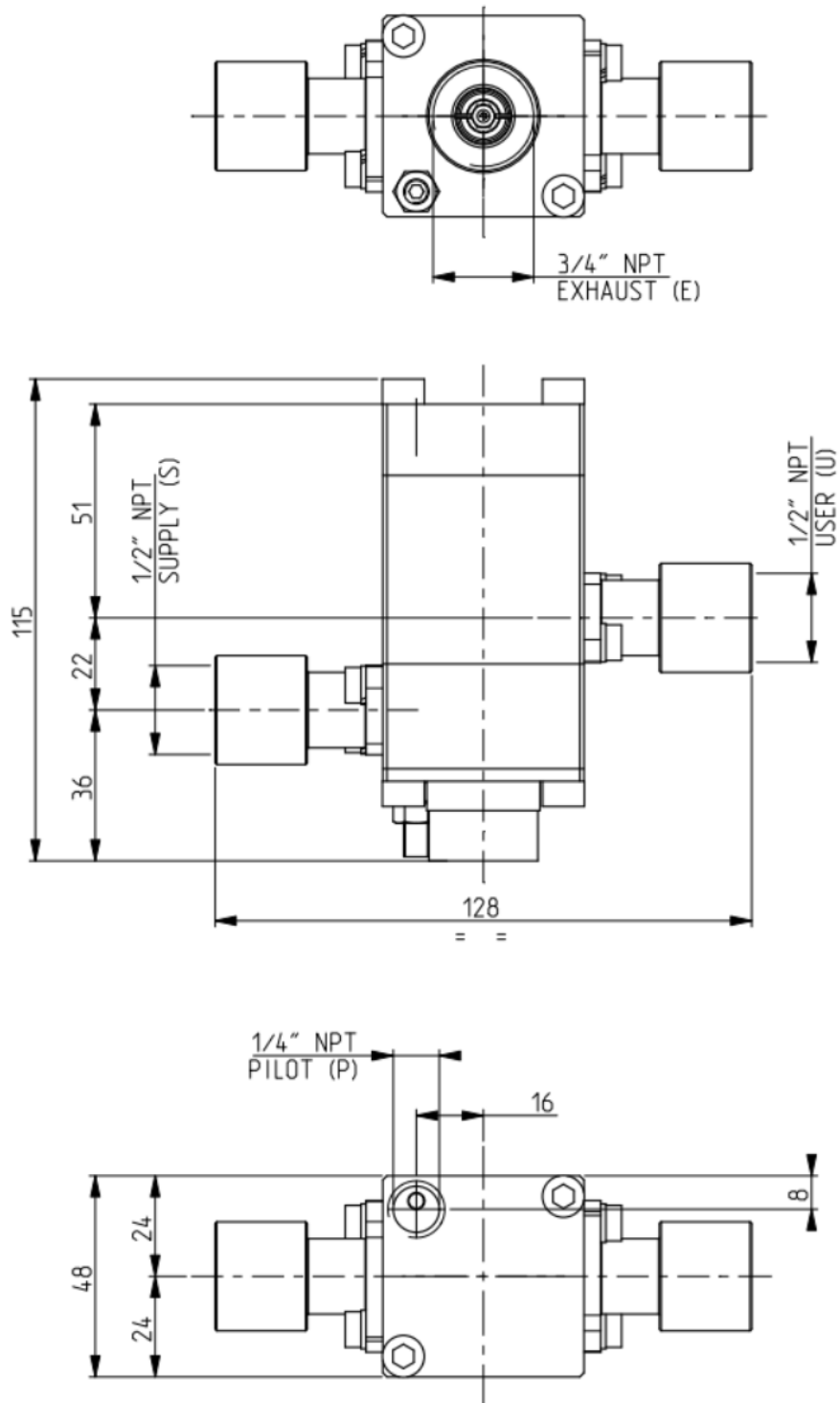

Figure 3 - Dimensional drawing BR-08SSH00 / BR-08SSS00 / BR-08SSL00

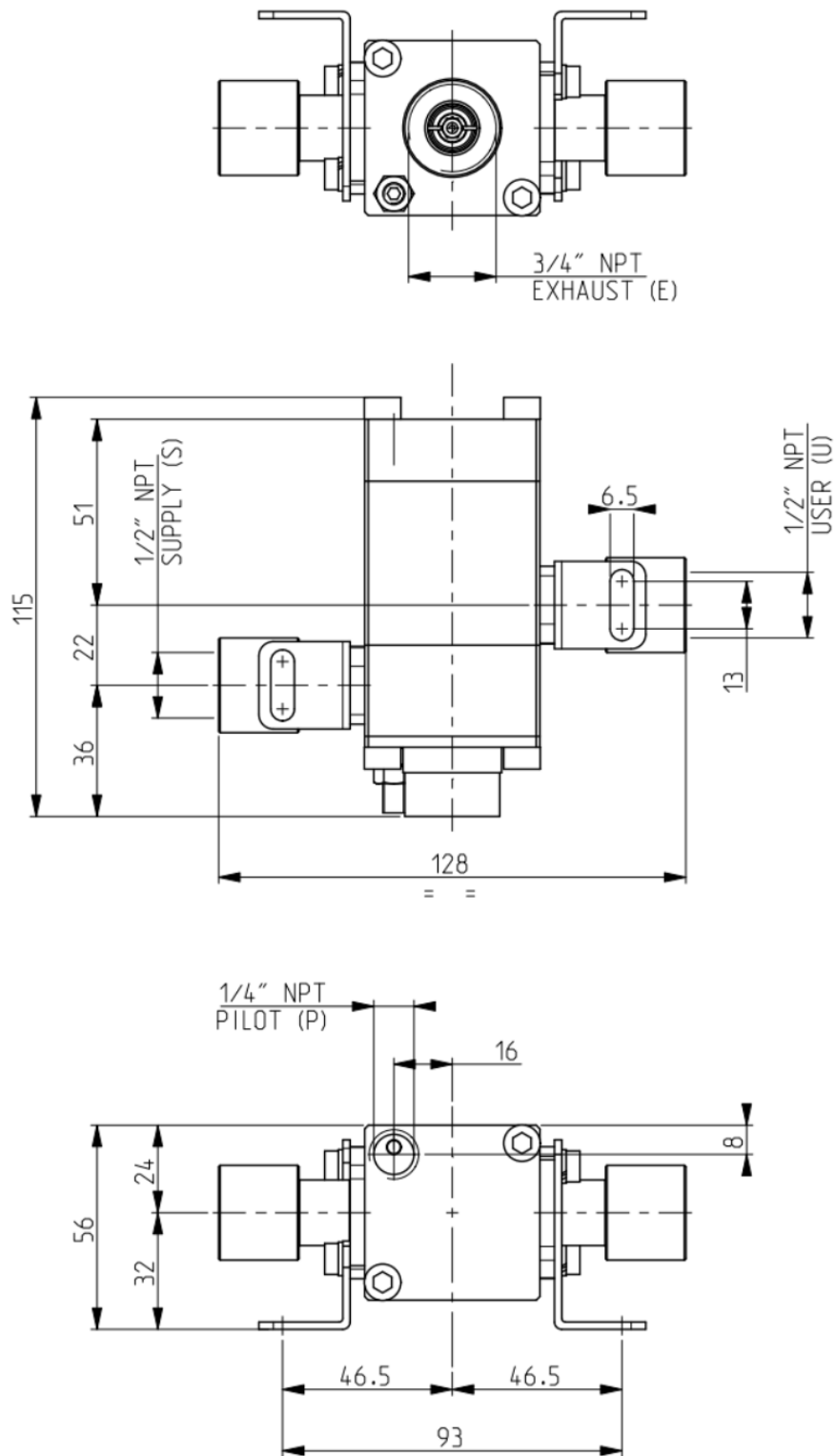



Figure 4 - Dimensional drawing BR-08SSH01 / BR-08SSS01 / BR-08SSL01

### 5.6.3 Pneumatic connections

<p><b>Warning</b></p> 	<p>Check that the values of pneumatic supply available are compatible with those reported on the BR body. Use pipes and connections appropriate as for type, rating, material and dimensions. The connection should be made by qualified staff.</p>
---	---

- Properly deburr the ends of rigid pipes.
- Properly clean the interior of pipes sending through them plenty of the supply fluid used in the system.
- Mould and fasten the connection pipes so that no irregular strains at entries or loosening of threaded connections occur.
- Use pipe sealant sparingly and only on male threads. A non-hardening sealant is strongly recommended.
- Make the connections according to the actuator pneumatic diagram.
- Check the absence of leakages from pneumatic connections. If necessary, tighten the nuts of the pipe-fittings.
- 8mm or 3/8" tubing are recommended as pilot from positioner.

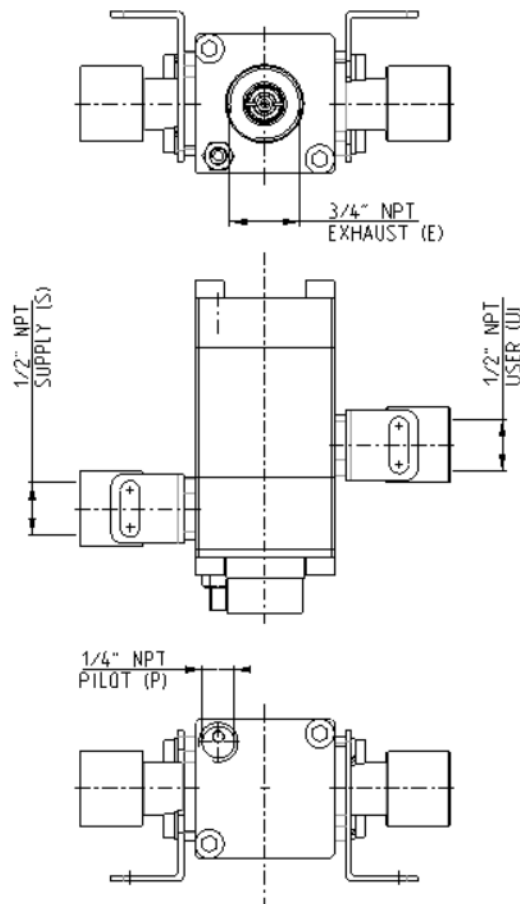



Figure 5 – Pneumatic connections

#### 5.6.4 Grounding connection

The earthing connection is guaranteed through the fixing screws of the BR. If the earthing connection of the system where BR is mounted is not guaranteed, it is necessary to ensure a direct earthing connection from the BR body.

## 5.7 Disassembling

<p>Warning</p> 	<p>Before starting the disassembly operations, it is mandatory to disconnect the pneumatic power and exhaust the BR. Cylinder chambers, pipes, fittings and accessories must not be under pressure. The staff must be qualified for the required operation.</p>
--	---



## 6 OPERATION AND USE

### 6.1 Operation description

Booster Relay BR has 2 main setups: charge and discharge. The by-pass stem may create a pressure drop depending on its adjustment and the working fluid flow rate.

In the charge setup the working fluid from the pilot passes through the by-pass connection:

- a) if the flow rate is lower than a threshold value depending on the by-pass stem adjustment, the by-pass stem throttling can't generate a pressure drop between the two side of the piston and the working fluid goes to the actuator chamber. This case is called "stand-by mode" (figure 6);
- b) if the flow rate is greater than a threshold value depending on the by-pass stem adjustment, the by-pass stem throttling generates a pressure drop between the two side of the piston and the working fluid pushes down the piston and the lower shutter, allowing the connection between the BR supply and the actuator chamber. This case is called "modulating mode" (figure 7);
- c) if the flow rate is much greater than a threshold value depending on the by-pass stem adjustment, the by-pass stem throttling generates a pressure drop between the two side of the piston and the working fluid pushes down the piston and the lower shutter, allowing the connection between the BR supply and the actuator chamber. In this case the lower shutter generates the greatest flow section available because the piston reaches its lower stroke limit. This case is called "on-off mode" (figure 8).

In the discharge setup the working fluid from the actuator passes through the valve shutter:

- a) if the flow rate is lower than a threshold value depending on the by-pass stem adjustment, the by-pass stem throttling can't generate a pressure drop between the two side of the piston and the working fluid goes to the pilot. This case is called "stand-by mode" (figure 9);
- b) if the flow rate is greater than a threshold value depending on the by-pass stem adjustment, the valve shutter throttling generates a pressure drop between the two side of the piston and the working fluid pushes up the piston, allowing the connection between the actuator chamber and the exhaust. This case is called "modulating mode" (figure 10);
- c) if the flow rate is much greater than a threshold value depending on the by-pass stem adjustment, the by-pass stem throttling generates a pressure drop between the two side of the piston and the working fluid pushes up the piston, allowing the connection between the actuator chamber and the exhaust. In this case the upper shutter generates the greatest flow section available because the piston reaches its upper stroke limit. This case is called "on-off mode" (figure 11).

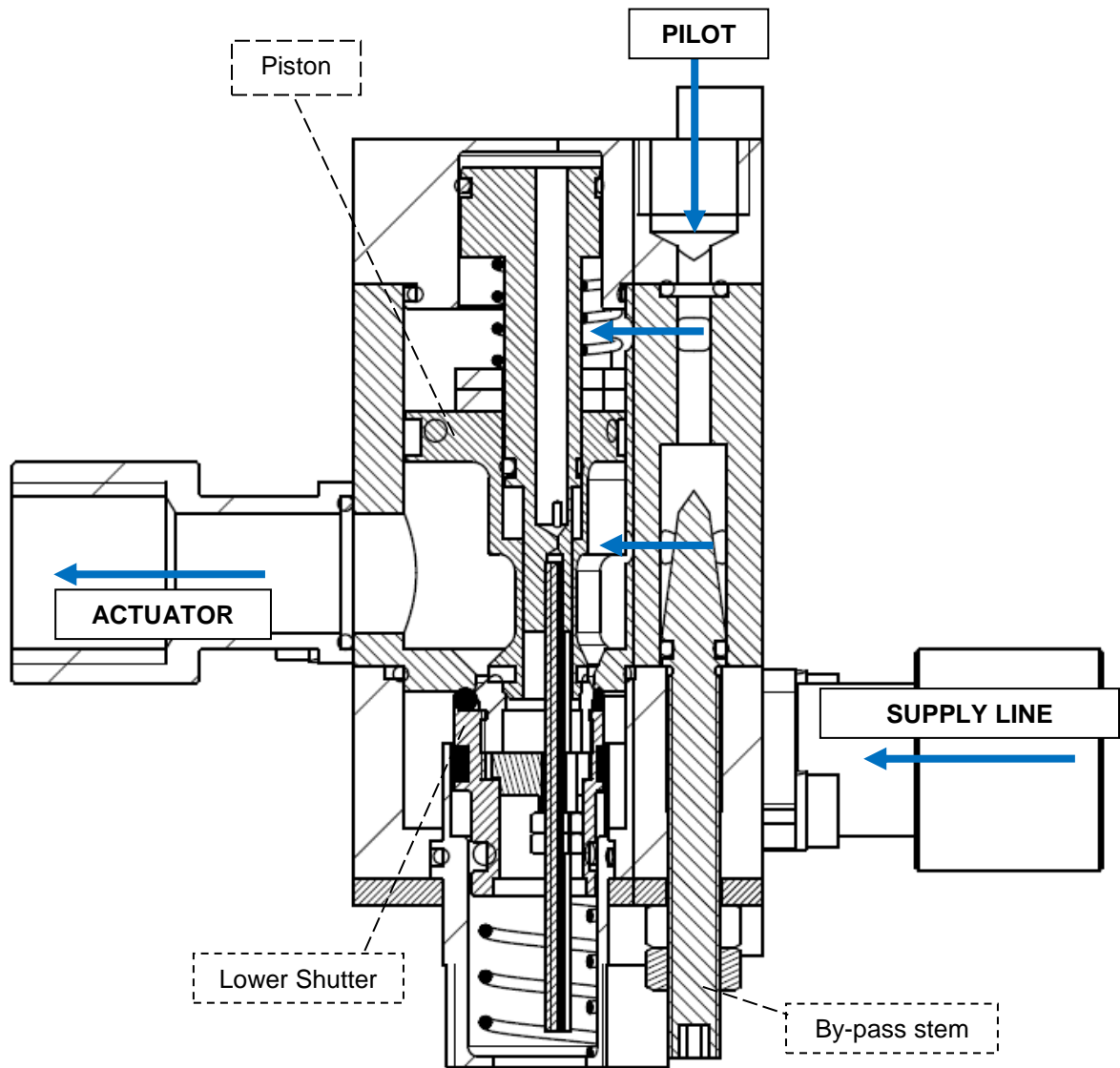

Figure 6 – Charge setup: stand-by model

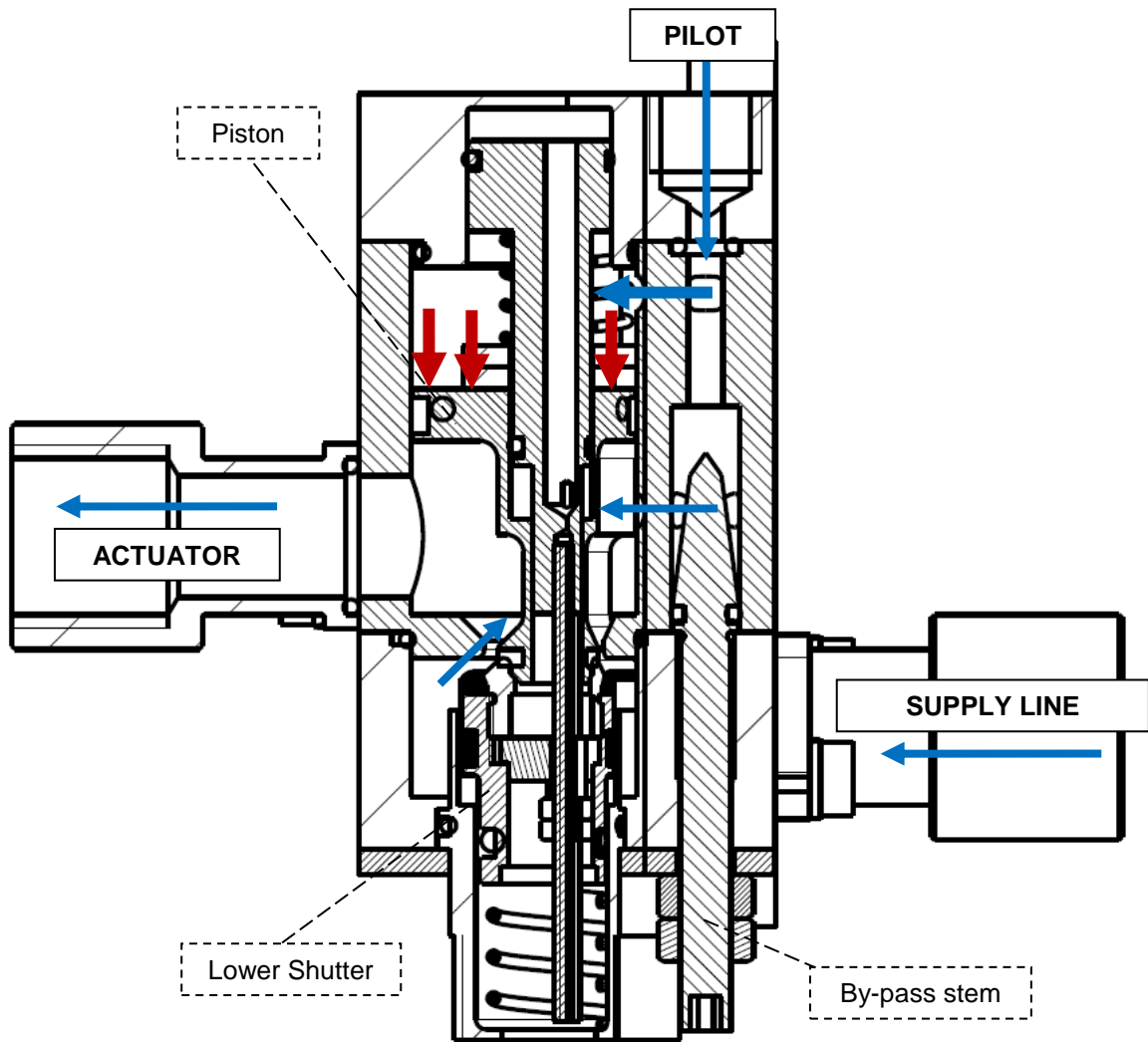

Figure 7 – Charge setup: modulating model

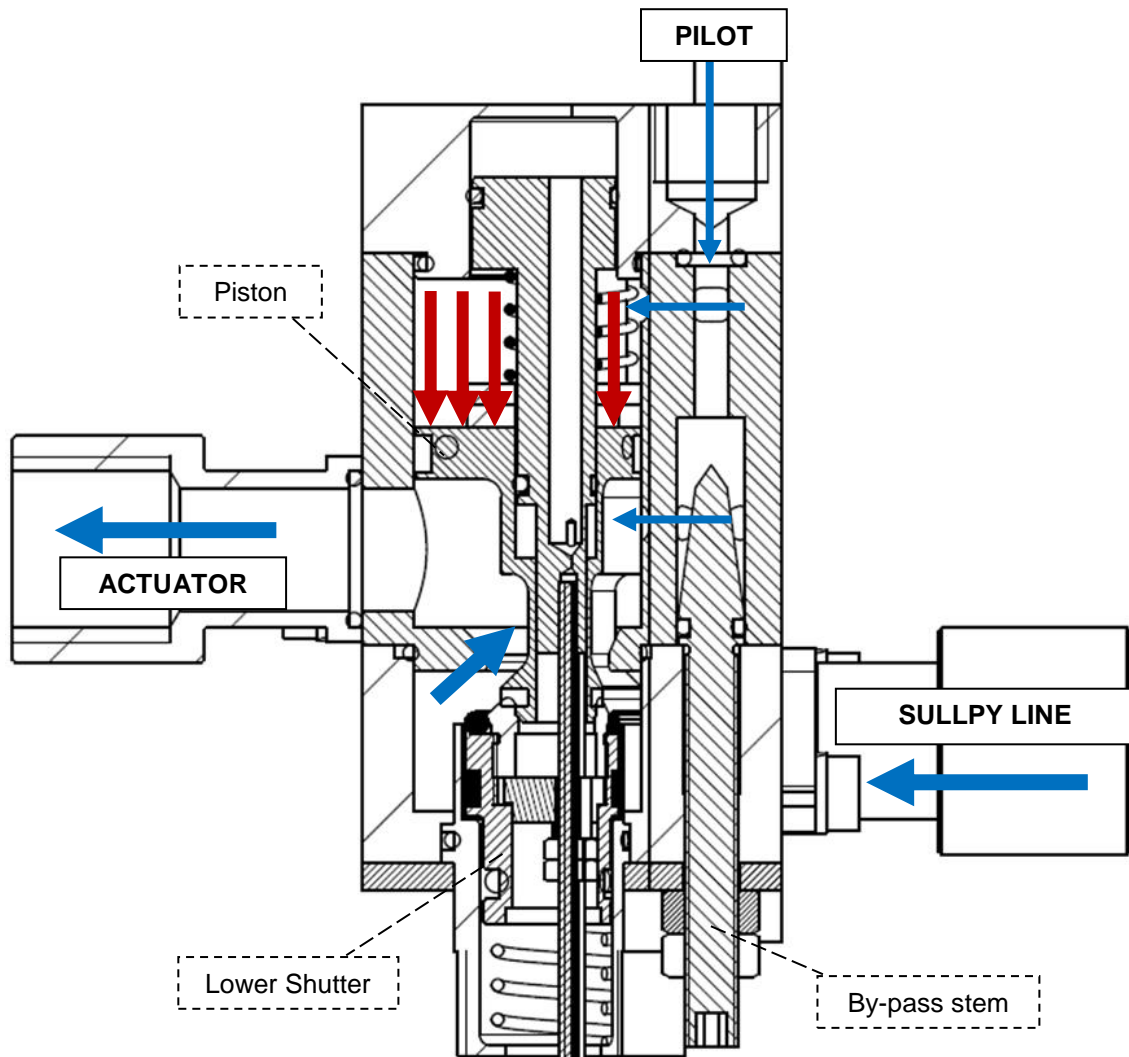

Figure 8 – Charge setup: on-off model

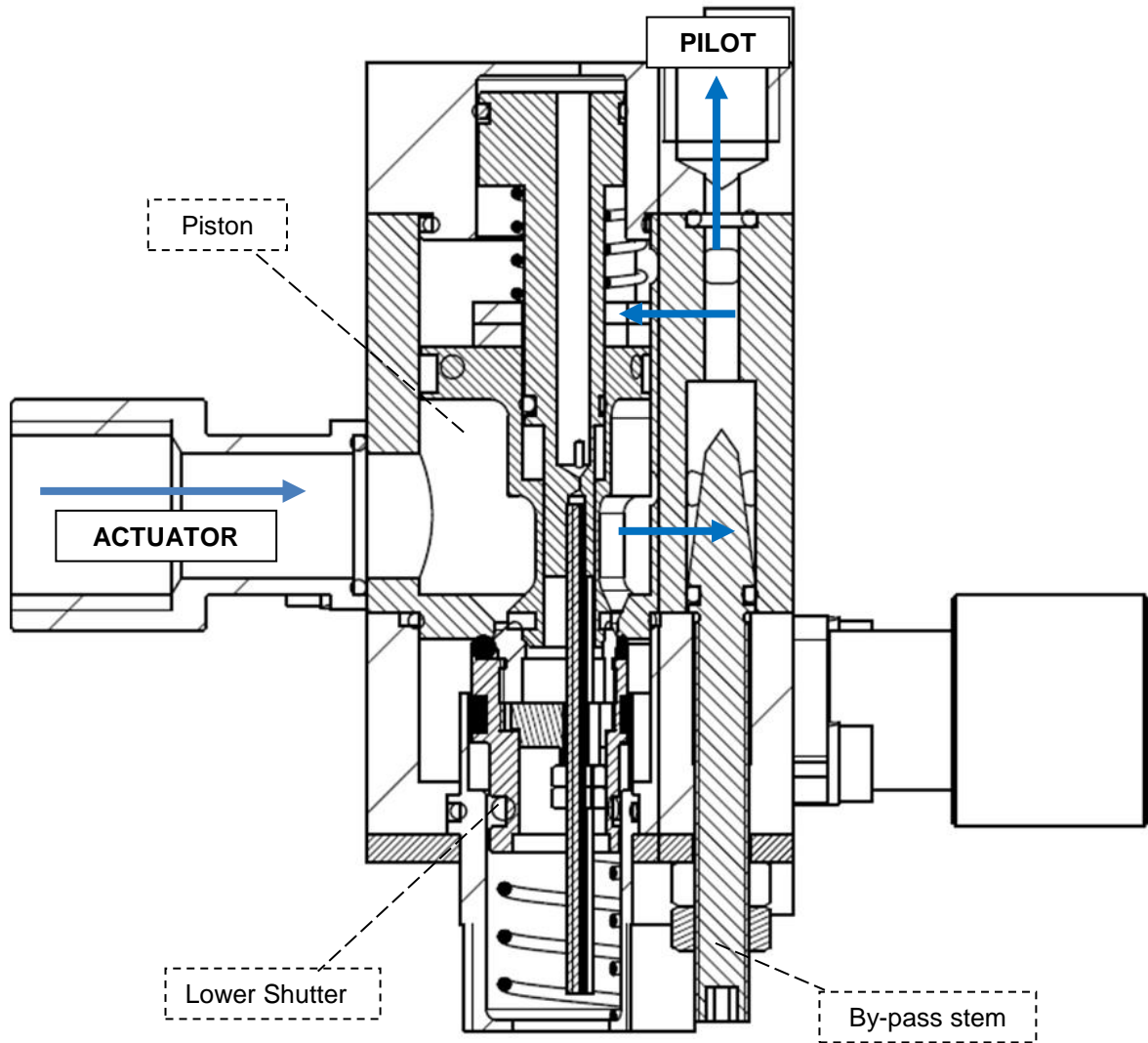

Figure 9 – Discharge setup: stand-by model

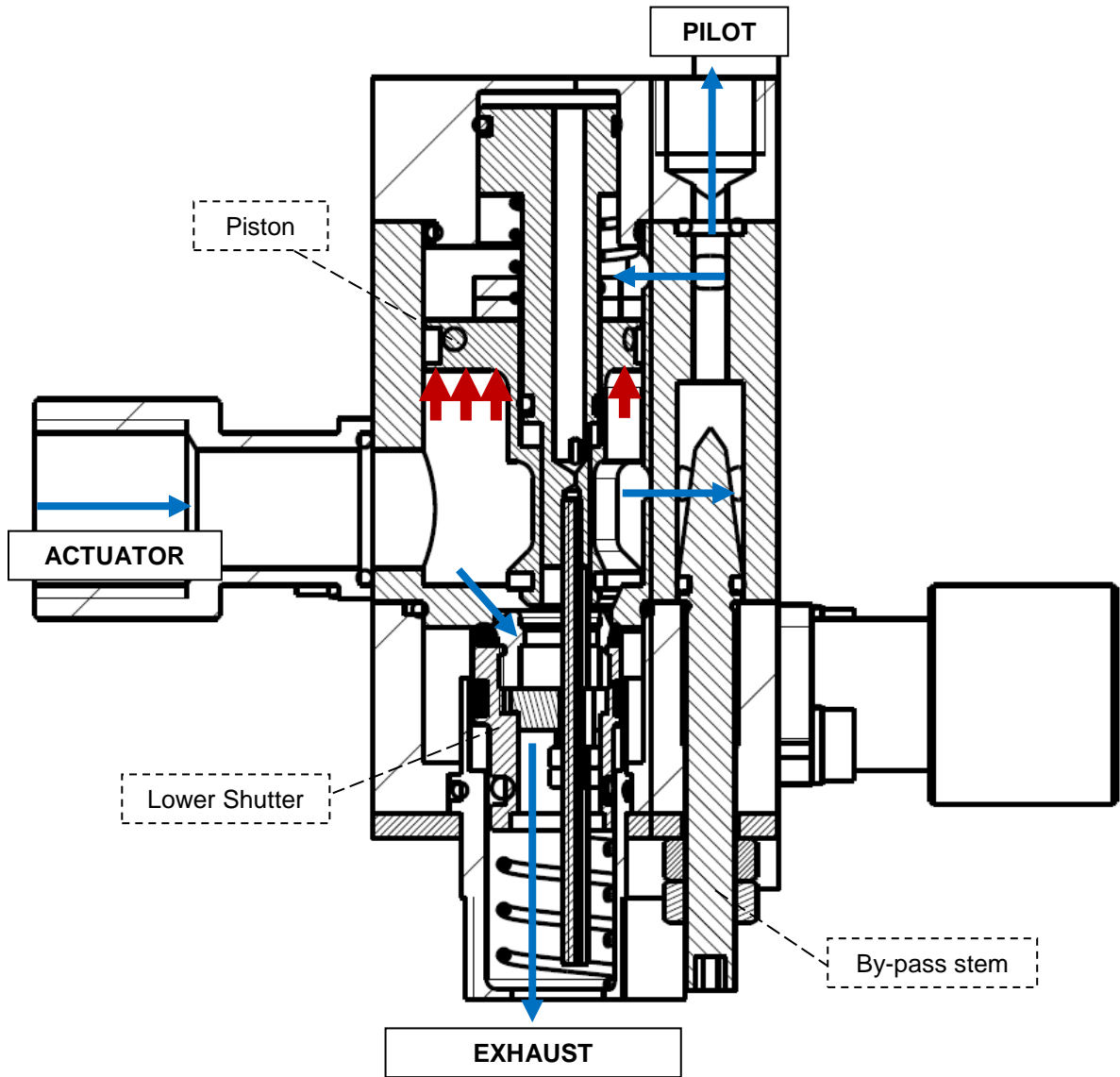

Figure 10 – Discharge setup: modulating model

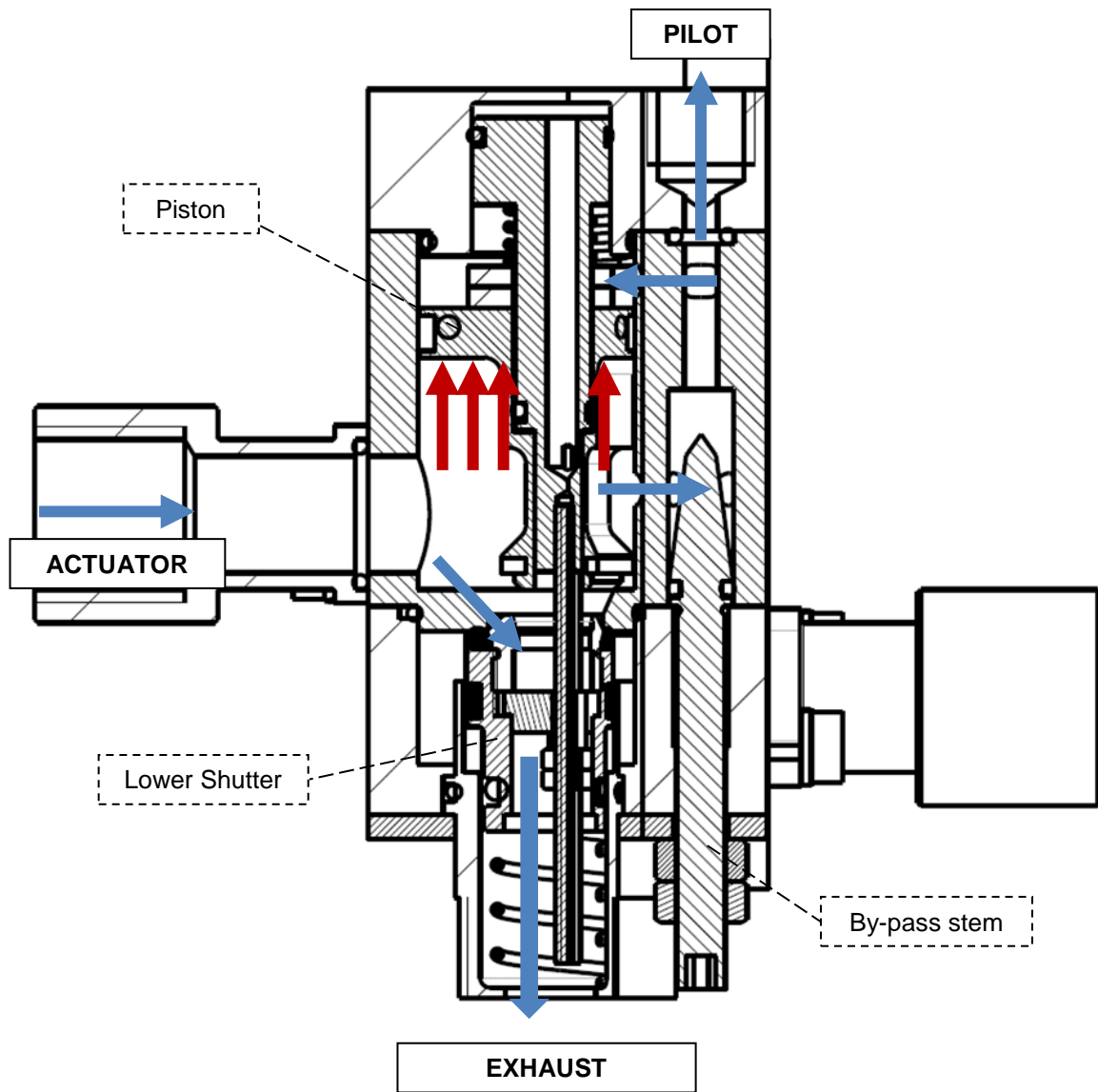

Figure 11 - Discharge setup: on-off model

## 6.2 Intended use

<p><b>Warning</b></p> 	<p><b>It is severely forbidden to use the BR for purpose or application other than those for which it was designed and here above specified.</b></p>
---	--

BR is produced by STI S.r.l. and identified on its body. STI S.r.l. will not be liable for any possible damage or physical injury resulting from use in other than the designated applications or by lack of care during installation, operation, adjustment or maintenance of the machine. Such risks lie entirely with the user. Depending on the specific working conditions, additional precautions may be requested. Considering that STI S.r.l. has no direct control over applications, operation or maintenance conditions, it is the operator's responsibility to comply with all applicable safety rules. Please inform STI S.r.l. urgently if you face unsafe situations not described in this Instruction Manual. It is the sole responsibility of the operator to ensure that the local health and safety regulations are adhered to.

BR is designed in accordance with the applicable International Rules and Specifications, but the following Regulations must be observed in any case:

- the general and safety regulations;
- the plant specific regulations and requirements;
- the proper use of personal protective devices (glasses, clothing, gloves, etc);
- the proper use of tools and transport equipment.

## 6.3 Reasonably foreseeable misuse

A short list of reasonably foreseeable misuse:

- installation in ambient with not planned conditions: i.e. climatic conditions different from the specified conditions.
- insert incorrect fluid into the system;
- supply pressure out of required range.

## 6.4 Operating limits

<p><b>Warning</b></p> 	<p><b>It is severely forbidden to use the BR under conditions other than those provided on its body.</b></p>
---	--

The BR label reports the main operating conditions for the specified application.



## 6.5 Residual Risks

<p><b>Warning</b></p> 	<p><b>The BR has parts under pressure. Use the due caution. Use individual protections provided for by the laws and provisions in force.</b></p>
---	--

- Risk due to movements of loads during mounting phase.
- Crushing during assemblage servicing.
- Extreme metal temperature at high (over than 80°C) or very low values as consequence of ambient temperature as to be considered as a risk of person injury in case of contact.
- Emissions of hazardous substances where natural gas is used as motive energy.

## 7 Instructions for the operator

During the start-up of the BR, proceed as follows:

- check that the pressure and quality of the air supply (filtering degree, dehydration) are as prescribed;
- check that there are not leaks in the pneumatic connections. If necessary, tighten the nuts of the pipe fittings;
- prior to operation, turn the by-pass stem counter clockwise to the fully opened position. With the actuator in operation, slowly turn the bypass screw until the booster operates in response to large changes in the input signal yet allows small changes to move the actuator without booster firing.

## 8 MAINTENANCE

### 8.1 Periodic Inspections

<p><b>Warning</b></p> 	<p>Take care that a build-up of dust or dirt on the BR can inhibit cooling and contribute to increase surface temperature. The user should plan and provide for a periodic cleaning / maintenance program that will maintain the external surface of the BR free from excessive layer of dust. Operation and maintenance shall be carried out by skilled staff.</p>
---	---

### 8.2 Special maintenance

Under normal condition the BR don't need special maintenance. In case of special maintenance send back the device to STI S.r.l. for any repairing and functional test.

### 8.3 Repairs

Repairs must not be carried out. When needed send back the device to STI S.r.l for any repairing and functional test.

### 8.4 Reassembling

Disassembling must not be carried out. When needed send back the device to STI S.r.l for any repairing and functional test.

### 8.5 Mechanism Lubrication

<p><b>Important</b></p> 	<p>BR does not need lubrication during Its life.</p>
---	--

## 9 PARTS LIST GENERAL ASSEMBLY

### 9.1 BR assembly – BR-08SSH00 / BR-08SSS00 / BR-08SSL00

N°	Quantity	Description
1	1	Main body
2	1	Supply body
3	1	Shutter body
4	1	Shutter cap
5	1	Pilot body
6	1	Piston
7	1	Exhaust cylinder
8	1	Exhaust flange
9	1	By-Pass stem
10	1	Gasket
11	1	Sealing ring OR 3100
12	2	Ball
13	2	Screw TCEI
14	2	Screw TCEI
15	2	Normal nut
16	1	Sealing ring OR 3056
17	1	Sealing ring OR 3075
18	1	Sealing ring OR 2100
19	1	Sealing ring OR 2137
20	2	Sealing ring OR 2018
21	2	Sealing ring OR 2056
22	1	Balancing plate
23	1	Stem for shutter
24	1	Piston guide
25	1	Piston sliding ring
26	1	Sealing ring OR 2037
27	1	Sealing ring OR 2081
28	1	Sealing ring OR 2125
29	2	Flat washer
30	1	Dim spring
31	1	Dim spring
32	2	Normal nut
33	2	Bracket
34	4	Lock washer
35	4	Screw TCEI

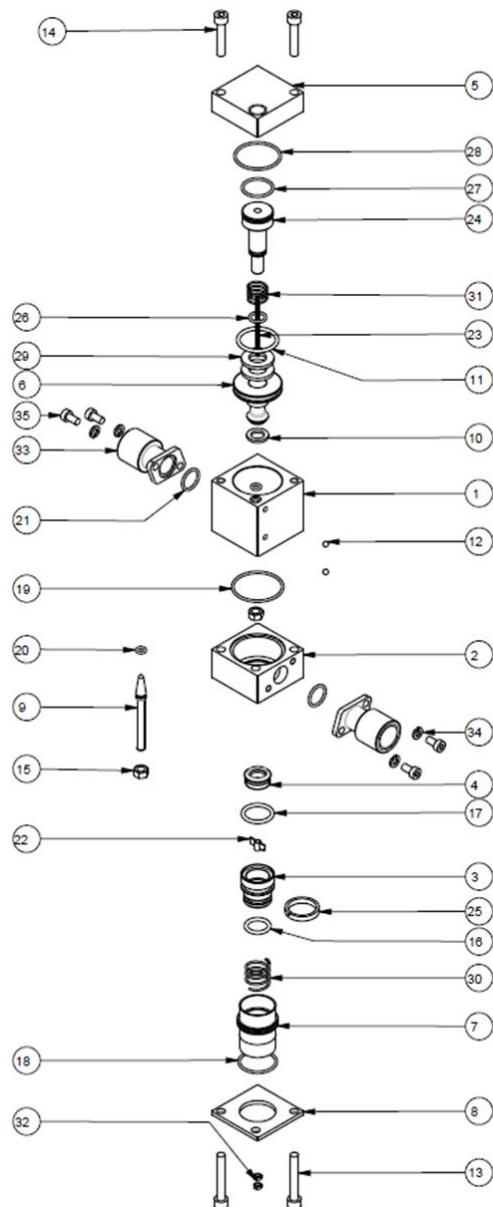

## 9.2 BR assembly – BR-08SSH01 / BR-08SSS01 / BR-08SSL01

N°	Quantity	Description
1	1	Main body
2	1	Supply body
3	1	Shutter body
4	1	Shutter cap
5	1	Pilot body
6	1	Piston
7	1	Exhaust cylinder
8	1	Exhaust flange
9	1	By-Pass stem
10	1	Gasket
11	1	Piston sliding ring
12	2	Ball
13	2	Screw TCEI
14	2	Screw TCEI
15	2	Normal nut
16	1	Sealing ring OR 3056
17	1	Sealing ring OR 3075
18	1	Sealing ring OR 2100
19	1	Sealing ring OR 2137
20	2	Sealing ring OR 2018
21	2	Sealing ring OR 2056
22	1	Balancing plate
23	1	Stem for shutter
24	1	Piston guide
25	1	Piston sliding ring
26	1	Sealing ring OR 2037
27	1	Sealing ring OR 2081
28	1	Sealing ring OR 2125
29	2	Flat washer
30	1	Dim spring
31	1	Dim spring
32	2	Normal nut
33	2	Bracket
34	2	NPT flange
35	4	Lock washer
36	4	Screw TCEI

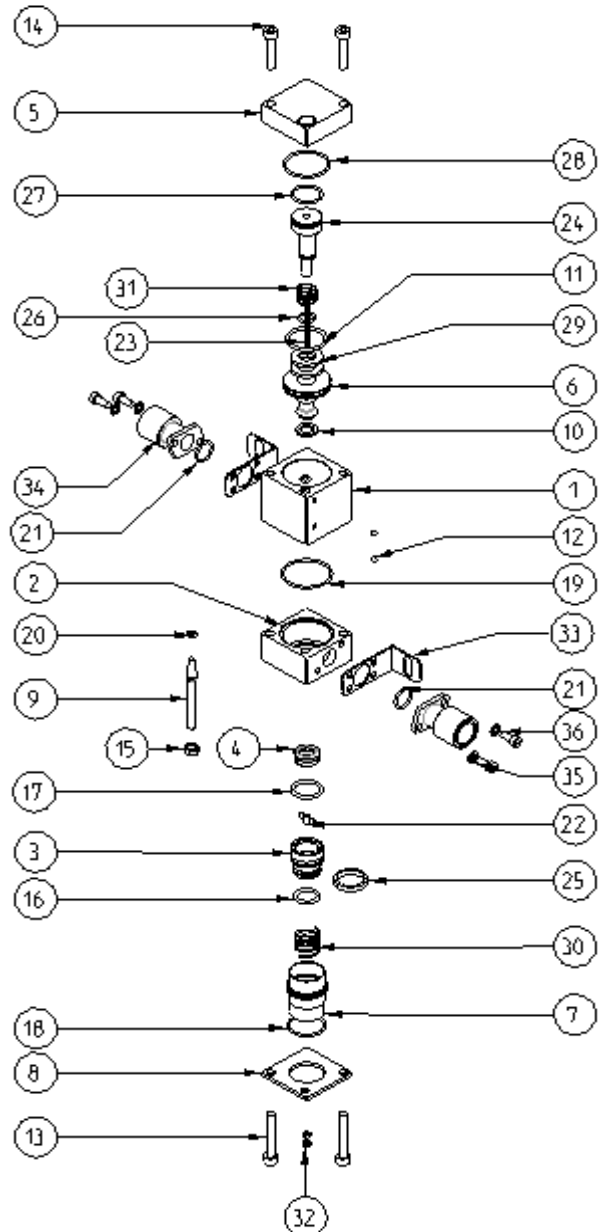

## 10 TROUBLESHOOTING

Event	Possible cause	Remedy
Booster doesn't work properly	Lack of pneumatic supply	Check supply line
	Low supply pressure	Adjust supply pressure
	Uncorrected by-pass stem adjustment	See Instruction for the operator
	Defective internal component (shutters, piston, ecc.)	Call STI S.r.l.
Leakages on pneumatic circuits	Deterioration and/or damage to gasket and/or loosed fittings	Call STI S.r.l.
	Damage to fittings	Call STI S.r.l.

## 11 SPARE PARTS

Repairs must not be carried out due to the calibration required during the mounting phase. When needed send back the device to STI S.r.l or the nearer STI Authorized Centre.

## 12 DECOMMISSIONING

Subject	Hazardous	Recyclable	Disposal
Metals	No	Yes	Use licensed recyclers
Plastics	No	Yes	Use specialist recyclers
Rubber (seals and O-rings)	Yes	No	May require special treatment before disposal, use specialist waste disposal companies
Oil and grease	Yes	Yes	May require special treatment before disposal, use specialist waste disposal companies

<b>Warning</b> 	<p>Before starting the disassembly operations, it is mandatory to disconnect the pneumatic power and to exhaust the BR. Cylinder chambers, pipe fittings and accessories must not be under pressure. The staff must be qualified for the required operation.</p> <p>The demolition of BR parts should be made from specialized personnel.</p>
--	---

<b>Warning</b> 	<p>The demolition of BR parts should be made from specialized personnel.</p>
---	--

<b>Important</b> 	<p>In all cases check local authority regulation before disposal.</p>
---	---



**IMI STI - Headquarters**

Via Dei Caravaggi 15  
24040 Levate (BG)  
Italy

Tel. +39 035 2928.2  
Fax +39 035 2928.247

**IMI STI – Quarter Turn Division**

Via San Francesco 18  
29017 Fiorenzuola d'Arda (PC)  
Italy

Tel. +39 035 2928.2  
Fax +39 0523 1715.295

**IMI Critical Engineering**

Lakeside, Solihull Parkway  
Birmingham Business Park  
Birmingham B37 7XZ  
United Kingdom

Tel. +44 (0)121 717 3700  
Fax +44 (0)121 717 3701

[www.imi-critical.com](http://www.imi-critical.com)  
[imisti.sales@imi-critical.com](mailto:imisti.sales@imi-critical.com)