

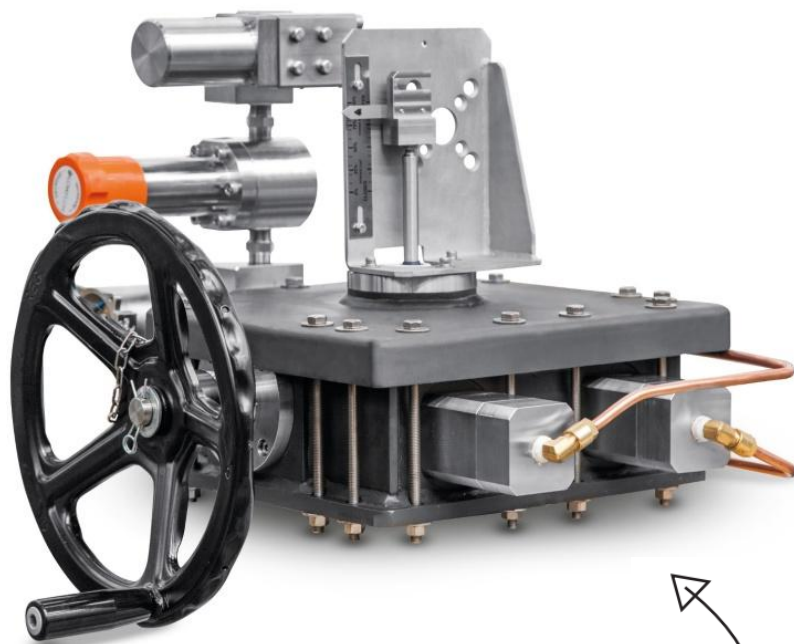

SM - VALVE ACTUATOR STEPPER MOTOR INSTRUCTION MANUAL 5019



Engineering
GREAT Solutions

STI S.r.l. has taken every care in collecting and verifying the documentation contained in this Instruction Manual. The information herein contained are reserved property of STI S.r.l.

INDEX

1	GENERAL INFORMATION	4
1.1	GENERALITIES	4
1.2	MANUFACTURER.....	4
1.3	TERMS AND CONDITIONS	4
1.4	MANUFACTURER’S LIABILITY	4
1.5	APPLICABLE STANDARDS AND DIRECTIVES	5
1.6	SYMBOLGY USED.....	5
2	DEVICE DESCRIPTION	6
3	TECHNICAL DATA.....	7
4	LABEL.....	9
5	OPERATING CONDITIONS AND INTENDED USE.....	10
5.1	OPERATING CONDITIONS.....	10
5.2	INTENDED USE.....	10
6	TRANSPORT	11
7	RECEPTION.....	11
8	STORAGE.....	11
9	INSTALLATION	12
9.1	CHECKS TO BE PERFORMED BEFORE INSTALLATION	12
9.2	SM VALVE ACTUATOR INSTALLATION.....	12
9.3	HYDRAULIC/PNEUMATIC CONNECTIONS	18
9.4	EARTHLING CONNECTION	18
10	INSTRUCTION FOR THE OPERATORS	19
10.1	FIELD ACTIVITIES	19
10.2	RESIDUAL RISKS	19
11	MAINTENANCE	20
11.1	PERIODIC INSPECTIONS AND MAINTENANCE.....	20
11.2	EXTRAORDINARY MAINTENANCE	20
11.3	GREASES.....	21
12	PARTS LIST GENERAL ASSEMBLY	22
13	TROUBLESHOOTING	25
14	SPARE PARTS	25
15	DISASSEMBLING.....	25
16	DECOMMISSIONING.....	26

1 GENERAL INFORMATION

Important	This Instruction Manual is an integral part of the machine, it should be carefully read before carrying out any operation and it should be kept for future references. The operators shall adopt the safety precautions required by the country where the product is installed. This Instruction Manual is realized in accordance with the Directive 2006/42/CE.
------------------	---



1.1 Generalities

STI S.r.l. actuators are conceived, manufactured and controlled according to the Quality management System in compliance with EN ISO 9001 International Standard.

1.2 Manufacturer

With respect to Machinery Directive 2006/42/EC, the Manufacturer of the described SM valve actuator is STI S.r.l. as specified on the label.

STI S.r.l. Via Dei Caravaggi 15
24040 Levate (BG) Italy
Tel. +39 035 2928.2
Fax +39 035 2928.247
imisti.sales@imi-critical.com

1.3 Terms and conditions

STI S.r.l. guarantees each single product to be free from defects and to conform to current goods specifications. The warranty period is two years from the date of shipment to the first user. The warranty does not cover special products or components not covered by warranty in their turn by subcontractors. No warranty is given for products which have been subject to improper storage, improper installation, improper maintenance or which have been modified or repaired by unauthorised personnel.

1.4 Manufacturer's liability

The SM valve actuator is designed in accordance with the applicable International Rules and Specifications, but the following regulations must be observed in any case:

- the general and safety regulations;
- the plant specific regulations and requirements;
- the proper use of personal devices, protective devices (glasses, clothing, gloves, etc), tools and transport equipment.

STI S.r.l. declines all liability in the event of:

- use SM valve actuator in other applications than the designated ones;
- use of the SM valve actuator in contravention of local safety at work legislation;
- lack of care during transport, installation, operations, maintenances of the SM valve actuator or incorrect application of the instructions provided on the SM valve actuator label and in this manual;
- modifications or repairs without STI S.r.l. authorisation;
- work done on the unit by unqualified or unsuitable operators.

Considering that STI S.r.l. has no direct control over particular applications, operation or maintenance conditions, it is the operator's responsibility to comply with all applicable safety rules; it is the sole responsibility of the operator to ensure that the local health and safety regulations are adhered to. Depending on the specific working conditions, additional precautions may be requested. Please inform STI S.r.l. urgently if you face unsafe situations not described in this Instruction Manual.

1.5 Applicable Standards and Directives

EN ISO 12100:2010	Safety of machinery - General principles for design - Risk assessment and risk reduction
IEC 61508:2010	Functional safety of electrical / electronic / programmable electronic safety-related systems
2006/42/EC	Machinery Directive
97/23/EC	Pressure Equipments Directive (PED)
94/9/CE	Equipments used in potentially explosive atmospheres (ATEX)

1.6 Symbology used

Dangerous symbols: be careful where these symbols are shown, they indicate a potentially hazardous situation and they warn that if the steps are not properly performed, may result causing serious injury, death or long-term risks to the health of exposed persons.



GENERAL DANGER



DANGER POWER SUPPLY



CRUSHING HAZARD

Obligation symbols: if these symbols are shown, the corresponding direction shall be followed.



General obligation
(with the possible
supplementary
signboard)



Must wear
protective
clothing.



Must wear
protective
footwear.



Must wear
protective
helmet.



Must wear
protective
glasses



Must wear
earplugs

2 DEVICE DESCRIPTION

The SM valve actuator is made by four main parts:

- the hydraulic/pneumatic circuit group, with two actuators (CW actuator and CCW actuator) able to make the steps and move the mechanism inside the box. One of the actuator moves the mechanism clockwise, the other one in counterclockwise;
- the position transmitter group, located on the top of the actuator and directly connected to the valve stem;
- the manual override, located on the side of the SM actuator;

Different kind of hydraulic/pneumatic accessories could be mounting on the SM valve actuator depending on the performance required.

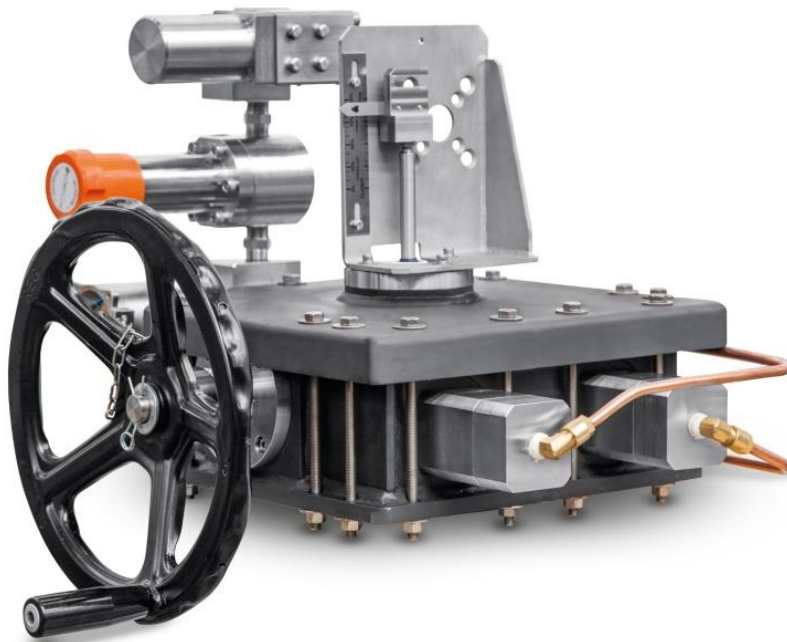
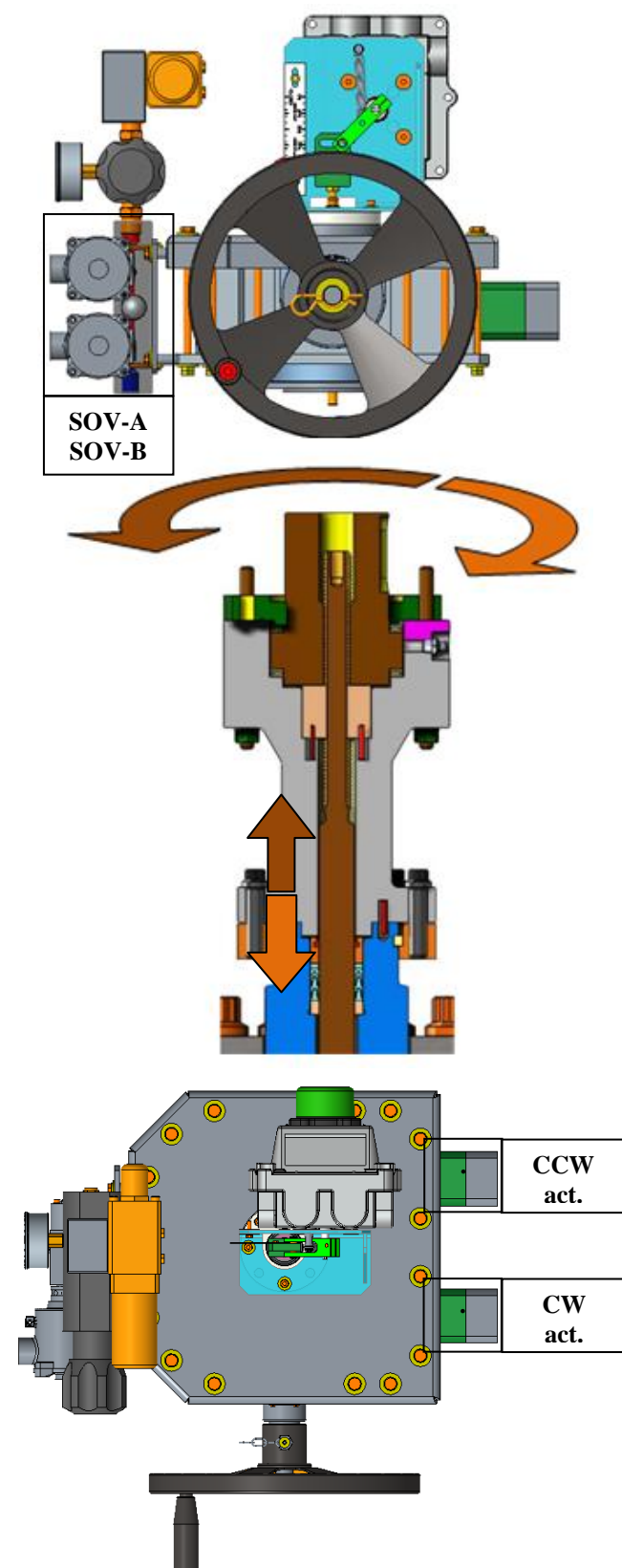

Figure 1 – SM valve actuator

3 TECHNICAL DATA

SM valve actuator	
 <p style="position: absolute; top: 350px; left: 140px; border: 1px solid black; padding: 2px;">SOV-A SOV-B</p> <p style="position: absolute; top: 700px; left: 440px; border: 1px solid black; padding: 2px;">CCW act.</p> <p style="position: absolute; top: 770px; left: 440px; border: 1px solid black; padding: 2px;">CW act.</p>	<p>SM Functional Description Valve closing</p> <ol style="list-style-type: none"> 1) The SOV-A managed the fluid inside the CW actuator. 2) The total SOV-A on/off time implies one CW step. 3) Each CW step rotates the SM mechanism of 1/15 turn clockwise. 4) The torque generated by each CW step is transformed in thrust by the thread on the valve stem. 5) The thrust value depends on the stem thread type. 6) The valve stem moves down as required. <hr/> <p>SM Functional Description Valve opening</p> <ol style="list-style-type: none"> 1) The SOV-B managed the fluid inside the CCW actuator. 2) The total SOV-B on/off time implies one CCW step. 3) Each CCW step rotates the SM mechanism of 1/15 turn counterclockwise. 4) The torque generated by each CCW step is transformed in thrust by the thread on the valve stem. 5) The thrust value depends on the stem thread type. 6) The valve stem moves up as required

SM valve actuator			
SM/H (Hydraulic)		SM/P (Pneumatic)	
Max Thrust (CW actuator)	2500 N	Max Thrust (CW actuator)	2500 N
Max Thrust (CCW actuator)	2500 N	Max Thrust (CCW actuator)	2500 N
Max Torque (on anti-rotation)	167 Nm	Max Torque (on anti-rotation)	167 Nm
Valve Stem Thread	ACME 7/8-8P (*)	Valve Stem Thread	ACME 7/8-8P (*)
Valve Operating Thrust	88000 N (*)	Valve Operating Thrust	88000 N (*)
Max Valve Stroke	100 mm	Max Valve Stroke	100 mm
Max Step SOV on/off	4 s	Max Step SOV on/off	4 s
CW/CCW Actuators Fluid	Oil	CW/CCW Actuators Fluid	Air
CW/CCW Actuators Design Pressure	206,9 bar (3000 psi)	CW/CCW Actuators Design Pressure	10 bar (145 psi)
Temperature Range	-30°C/+50°C (**)	Temperature Range	-30°C/+50°C (**)
Expected lifetime	20 years	Expected lifetime	20 years

(*) The Valve Operating Thrust depends on the Valve Stem Thread, thus different Valve Stem Thread types give different Valve Operating Thrusts (considering the same CW/CCW actuator thrust or the torque generated). The values reported in this table refers only to one application, but nothing exclude different Valve Operating Thrusts (lower or greater than the one reported);

(**) Optional: different temperature range.

4 LABEL

Every SM valve actuator is provided with a label contains the main operating conditions and serial number. The label may change if the SM valve actuator is sold with reference to a Certificate of product and/or system issued by Notified Body Exterior or Certificate of Conformity issued by STI.

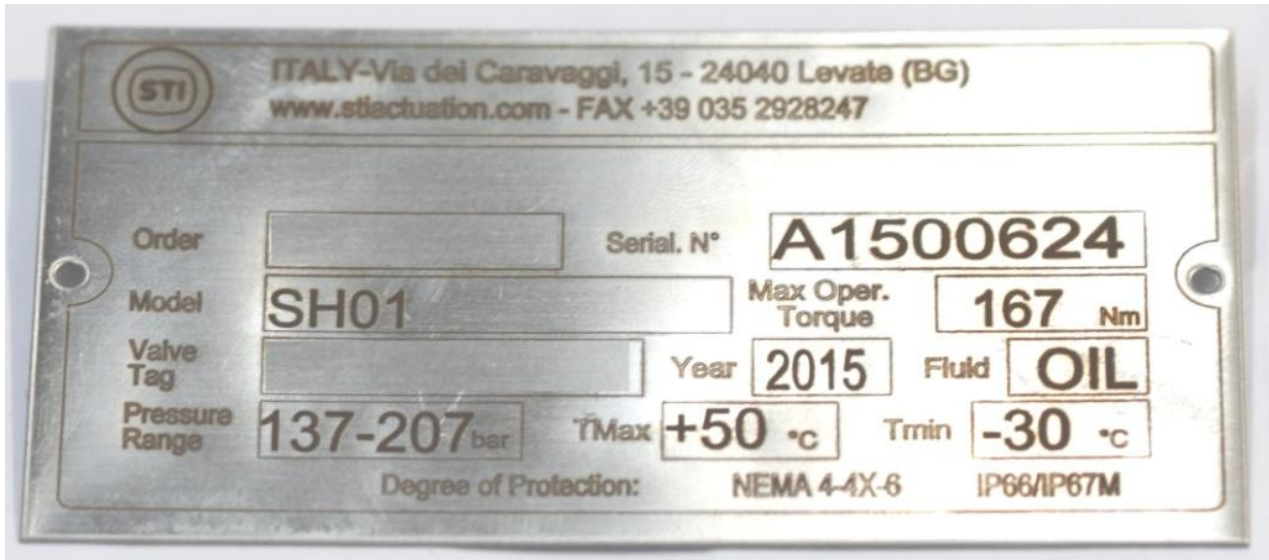





Figure 2 – SM standard label

<p>Warning</p> 	<p>It is severely forbidden to use the SM valve actuator under conditions other than those provided on the label.</p>
<p>Important</p> 	<p>It is forbidden to modify the information and the marks without previous written authorization by STI. Do not remove the label and/or replace with other label.</p>

5 OPERATING CONDITIONS AND INTENDED USE

Warning 	<p>It is severely forbidden to use the SM valve actuator for purpose or application other than those for which it was designed and here specified.</p>
---	---

5.1 Operating conditions

The label fastened on the SM valve actuator contains the main operating conditions for the specified application (see Section 4). Other operating conditions are reported on the documents accompanying the actuator. For general operating conditions see Section 3.

5.2 Intended use

The SM valve actuator series has been specifically designed in on-off application. In order to open/close the valve without the support of the supply fluid, the manual override is required. The manual override handwheel is detachable in order to avoid injuries for the operators due the rotation of the mechanism located inside the stepper motor.

Warning 	<p>In order to use the manual override, remove the pressure inside the hydraulic circuit and then fix the detachable handwheel on the shaft using the screw linked to the handwheel by a chain. After the manual override using take off the screw from the shaft / handwheel and restore the pressure.</p>
---	--

Important 	<p>The handwheel is always secured on the shaft by a cotter pin. Be careful to any unexpected rotation of the handwheel during the running of the actuator. In order to avoid any handwheel rotation, remove the pressure inside the hydraulic circuit and then take off the copper pin, the washer and the handwheel from the shaft. At the end restore the pressure.</p>
---	---

Important 	<p>During the running of the actuator, the manual override shaft is always engaged.</p>
---	--

After the manual override using, check the correct behavior of the SM valve actuator with a functional test or a visual check.

6 TRANSPORT

<p>Warning</p> 	<p>The following instructions must be respected:</p> <ul style="list-style-type: none"> - operations must be carried out only by skilled operators; - always wear protective clothing, gloves, and eyewear to prevent personal injury. Check with your process or safety engineer for any additional measures that must be taken to protect against process media.
---	---

<p>Important</p> 	<p>The lifting and handling should be made in compliance with the laws and provisions in force.</p>
---	--

Lift the SM valve actuator with belts, using its eyebolts. Make sure that the belts never scratches the accessories and hydraulic/electric connection.

7 RECEPTION

SM valve actuator leave the factory in perfect condition. Performances of each unit are guaranteed by tests and data reported on a specific Test Report. At the reception of the SM valve actuator:

- check that the model correspond with that of order confirmation;
- check that the hydraulic diagrams, wiring diagrams and dimensional drawing are furnished with document accompanying the actuator;
- check that the SM valve actuator was not damaged during transportation. If necessary renovate the painting according to the specification reported on the order confirmation.

8 STORAGE

In order to maintain the guaranteed actuator performances until the SM valve actuator is installed on site, proper attention must be observed for preservation during the storage period. If the SM valve actuator needs storage before installation:

- place it in a dry, clean place and take all necessary measures to avoid contact with dust, dirt and humidity during storage;
- make sure that connection protections and/or the mechanical locks will not be removed during the storage;
- storage temperature must be between -20°C and +40°C.

9 INSTALLATION

Warning 	<p>The following instructions must be respected:</p> <ul style="list-style-type: none"> - operations must be carried out only by skilled operators; - always wear protective clothing, gloves, and eyewear to prevent personal injury. Check with your process or safety engineer for any additional measures that must be taken to protect against process media.
---	--

Important 	<p>Not performing the following procedures will invalidate the product warranty.</p>
---	--



9.1 Checks to be performed before installation

It is recommended to check the SM valve actuator conditions before the installation, then:

- prepare the necessary tools for the assembly and setting of the unit;
- check that the coupling dimensions meet the specified coupling dimensions;
- clean the SM valve actuator surfaces and remove anything that might prevent a perfect adherence with the valve.

9.2 SM valve actuator installation

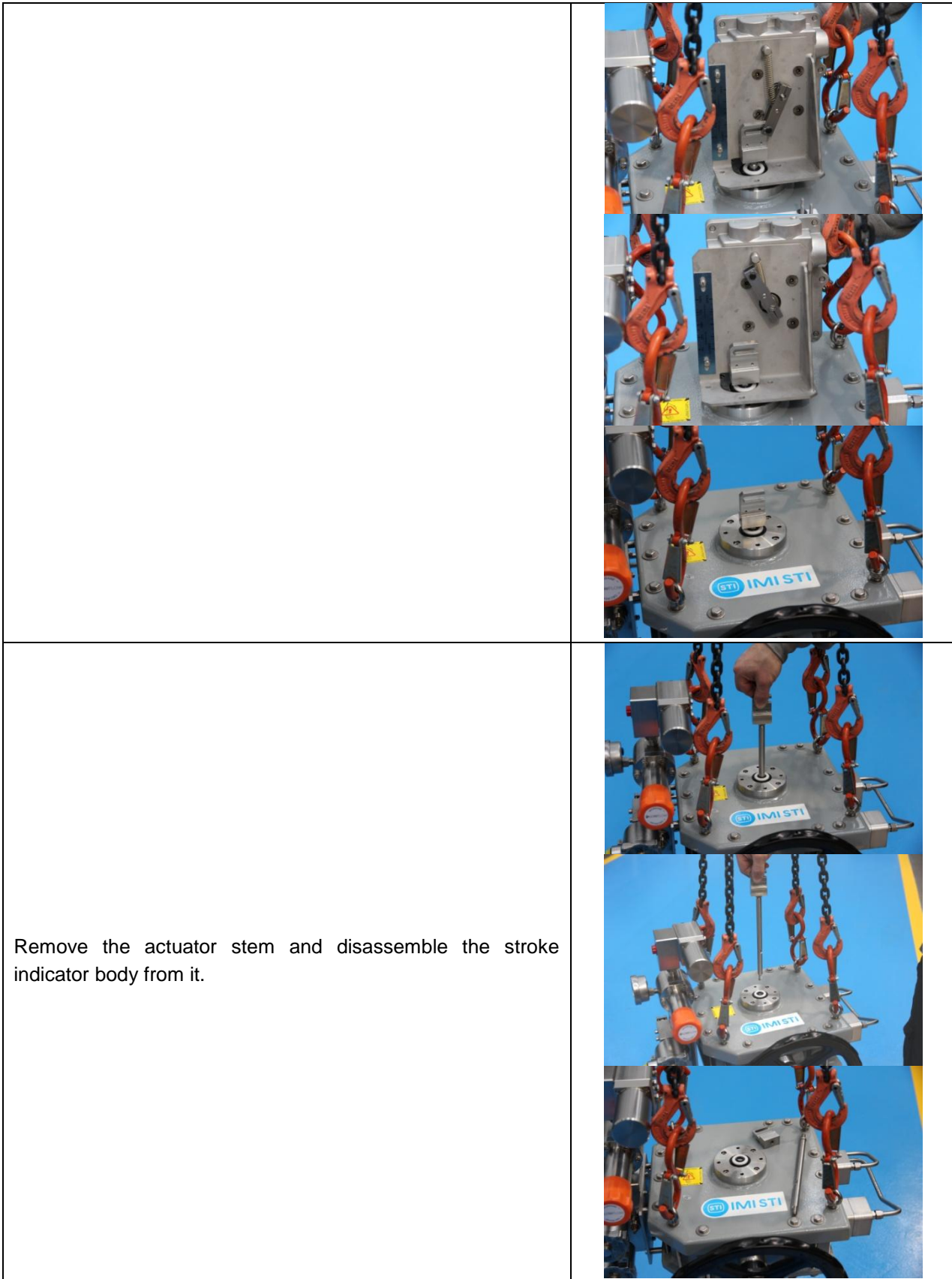

In order to perform a proper installation follow these steps.

<p>Hold the SM valve actuator using the eyebolts.</p>	
<p>Unscrew the n°3 M5 screws and take off the position transmitter group.</p>	

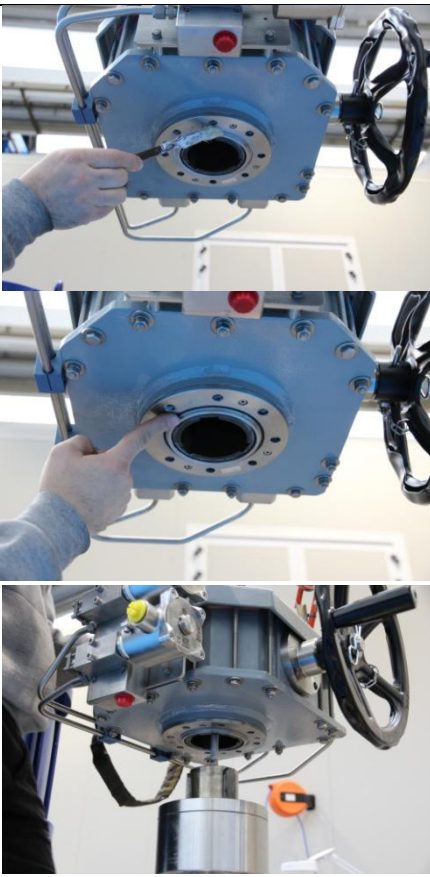
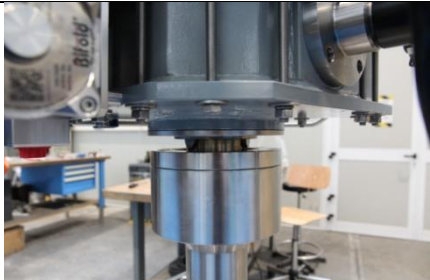

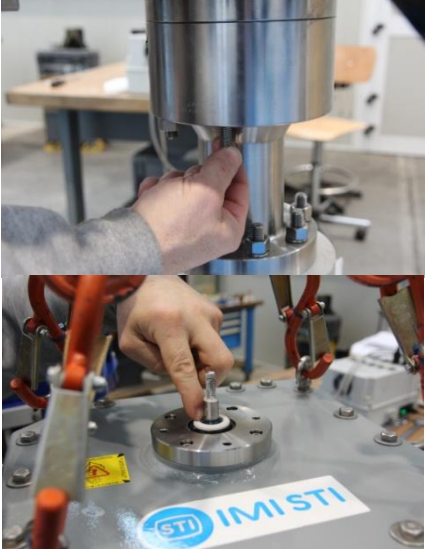
<p>Tighten the actuator stem in the valve stem and put the n°3 feather keys on the rotation nut of the valve.</p>	
<p>Mount the O-ring properly greased on the lower flange of the SM valve actuator and put the SM valve actuator over the valve.</p>	
<p>Mount the SM valve actuator on the valve by letting in the feather keys in their seats (the feather key seats are obtained in the internal step mechanism of the actuator). The register is made by the lower flange of the actuator. During this step pay attention that the actuator stem enters properly the dust seal of the top flange.</p>	

	
<p>Tighten the yoke tie rods and then push the dust seal in its seat.</p>	

<p>Warning</p> 	<p>Do not lift the valve with the SM valve actuator eyebolts.</p>	 <p>NON SOLLEVARE LA VALVOLA CON I GOLFARI DELL'ATTUATORE</p> <p>NO LEVANTAR LA VALVULA CON ARMELLAS DEL ACTUADOR</p> <p>DO NOT LIFT THE VALVE WITH ACTUATOR EYEBOLTS</p> <p>不要使用执行器上的吊环起吊阀门</p>
---	--	--

Mount the nut and the stroke indicator body, then tighten them.



Mount the transmitter position group and then the stroke indicator (using n°2 M3 screws).

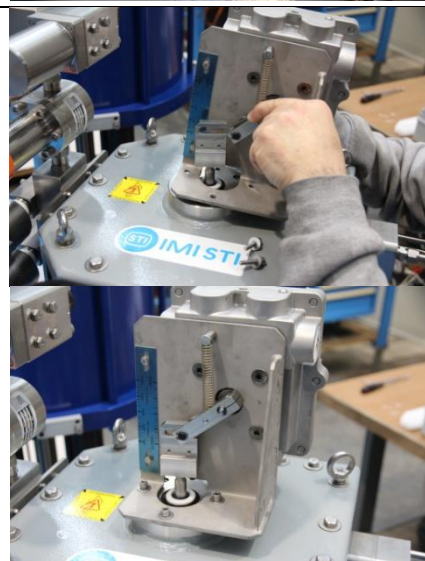

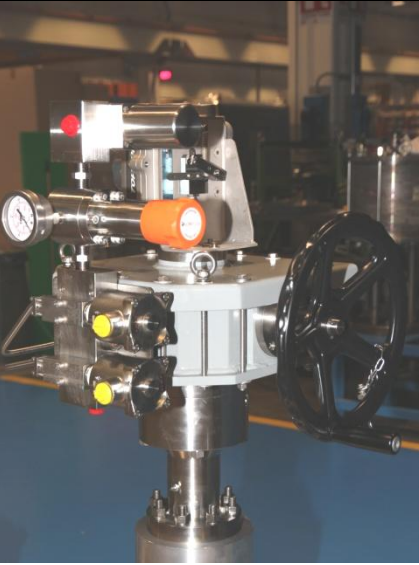
	
<p>At the end try to open /close the valve using the manual override (see 5.2).</p>	

9.3 Hydraulic/Pneumatic connections

<p>Warning</p> 	<p>Check that the values of hydraulic/pneumatic supply available are compatible with those reported on the label of the SM valve actuator.</p> <p>User must consider and take all precautions to avoid that pressurized parts are not used out of specified range and to avoid exposure to fire.</p>
---	--

It is required to follow this steps during the hydraulic/Pneumatic connection:

- no lubricators on supply fluid line is required;
- use pipes and connections appropriate as for type, rating, material and dimensions;
- properly deburr the ends of rigid pipes;
- properly clean the interior of pipes sending through them plenty of the supply fluid;
- use pipe sealant sparingly and only on male threads. A non-hardening sealant is strongly recommended;
- fasten the connection pipes so that no irregular strains or loosening of threaded connections occur;
- check the absence of leakages from connections. If necessary tighten the nuts of the pipe-fittings;
- after connecting the actuator, gradually increase the supply pressure up to the maximum operating pressure.

9.4 Earthing connection

<p>Warning</p> 	<p>Check if the SM valve actuator has a properly earthing connection.</p>
---	--

The earthing connection is guaranteed through the fixing flange of the SM valve actuator. If the earthing connection of the system where SM valve actuator is mounted is not guaranteed, it is required to ensure a directly earthing connection.

10 INSTRUCTION FOR THE OPERATORS

Warning 	<p>The following instructions must be respected:</p> <ul style="list-style-type: none"> - operations must be carried out only by skilled operators; - always wear protective clothing, gloves, and eyewear to prevent personal injury. Check with your process or safety engineer for any additional measures that must be taken to protect against process media.
---	--

Important 	<p>Any repair work other than the operations outlines in this Instruction Manual is allowed only if STI authorises it.</p>
---	--

10.1 Field activities

During the start-up of the SM valve actuator:

- check that the pressure and quality of the supply fluid (filtering degree, dehydration, etc) are as prescribed;
- check if the operating condition are as prescribed;
- check that there are no leak of the hydraulic/pneumatic connections;
- check that there are no leak of the accessories mounted on the SM valve actuator;
- check that there are no leak of the CW/CCW actuators of SM valve actuator;
- for any detail about the accessory mounted on the SM valve actuator see their instruction manuals;
- remove all rust on the SM valve actuator surfaces;
- repair paint-coat that has been damaged, in accordance with the applicable painting specifications;
- perform a complete functional test.

10.2 Residual Risks

Reasonably foreseeable misuse:

- risk due to movements of loads during transport and installation;
- crushing during transport and installation;
- installation in ambient with not planned conditions;
- metal temperature at high or very low values as consequence of ambient temperature as to be considered as a risk of person injury in case of contact;
- insert incorrect motive fluid into the system;
- supply pressure out of planned range.

11 MAINTENANCE

<p>Warning</p> 	<p>The following instructions must be respected:</p> <ul style="list-style-type: none">- operations must be carried out only by skilled operators (STI operators or operators qualified by STI are recommended);- always wear protective clothing, gloves, and eyewear to prevent personal injury. Check with your process or safety engineer for any additional measures that must be taken to protect against process media.
---	--

Before any type of operation and/or maintenance is performed, make sure that:

- actuator, accessories and all connected equipment are not under pressure and in safe conditions;
- fluid supply, power or other energy sources and signals are disconnected.

11.1 Periodic Inspections and maintenance

Periodic visual inspections are recommended. The user shall:

- plan and provide for a periodic cleaning/maintenance program that will maintain the external surface of the SM valve actuator free from excessive layer of dust.

11.2 Extraordinary maintenance

In case of extraordinary maintenance, following malfunction and related troubleshooting, proceed as written in Section 13.

11.3 Greases

CW/CCW actuators material	Very Low temperature (Tmin ≤ -40°C)	Low temperature (-40°C < Tmin < -20°C)	Standard temperature (-20°C ≤ T ≤ -70°C)	High temperature (Tmax > 70°C)
Aluminum	RHEOLUBE 361F (Tecnolube seal)	RHOESIL 500F (Tecnolube seal)	MOLYGUARD IDROSFER	SYNTHY 101 (Tecnolube seal)
Nickel plated carbon steel	RHEOLUBE 361F (Tecnolube seal)	RHOESIL 500F (Tecnolube seal)	MOLYGUARD IDROSFER	SYNTHY 101 (Tecnolube seal)
Chrome plated carbon steel	RHEOLUBE 361F (Tecnolube seal)	RHOESIL 500F (Tecnolube seal)	POLIMER 400/1 (Tecnolube seal)	SYNTHY 101 (Tecnolube seal)
Stainless steel	RHEOLUBE 361F (Tecnolube seal)	RHOESIL 500F (Tecnolube seal)	POLIMER 400/1 (Tecnolube seal)	SYNTHY 101 (Tecnolube seal)
Fiber	RHEOLUBE 361F (Tecnolube seal)	RHOESIL 500F (Tecnolube seal)	POLIMER 400/1 (Tecnolube seal)	SYNTHY 101 (Tecnolube seal)

Manual override material	Very Low temperature (Tmin ≤ -40°C)	Low temperature (-40°C < Tmin < -20°C)	Standard temperature	High temperature (Tmax > 70°C)
All material	MOLIKOTE	MU EP (Agip)	MU EP (Agip)	MU EP (Agip)

12 PARTS LIST GENERAL ASSEMBLY

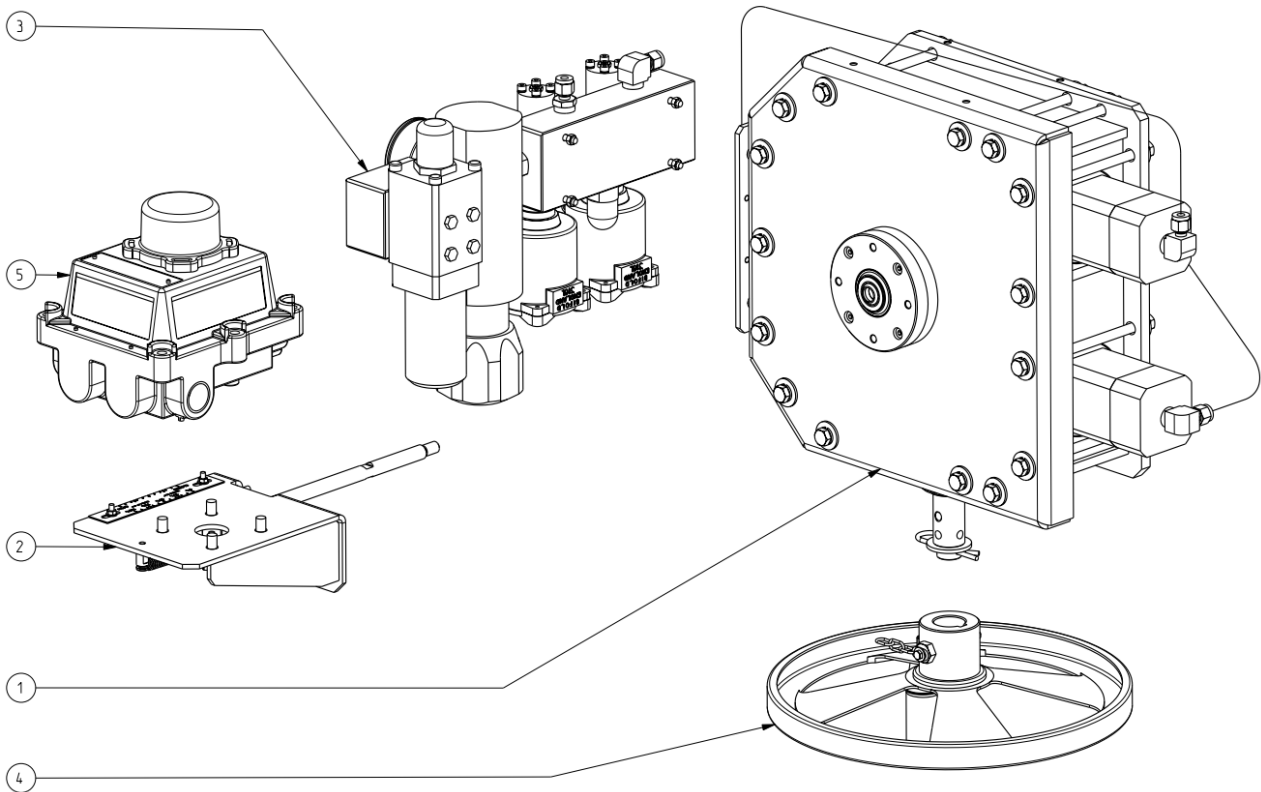

POS.	Q.TY'	DESCRIPTION
1	1	STEPPER
2	1	POSITION TRANSDUCER ASSEMBLY
3	1	MANIFOLD ASSEMBLY
4	1	SOLID TYPE HANDWHEEL
5	1	POSITION TRANSMITTER

Figure 3 – SM valve actuator

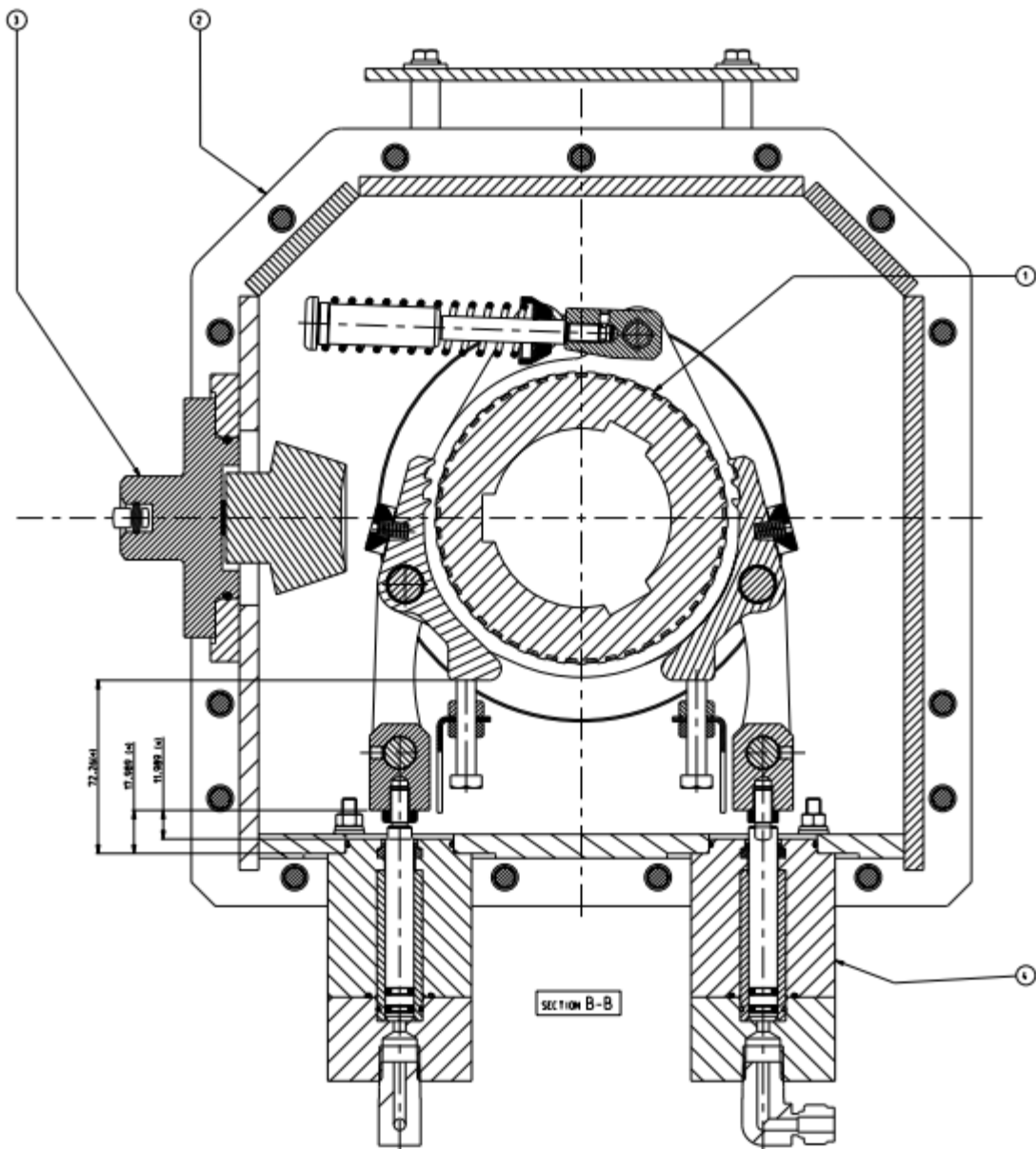

POS.	Q.TY	DESCRIPTION
1	1	MECHANISM ASSEMBLY
2	1	BOX ASSEMBLY
3	1	BEVEL GEAR ASSEMBLY
4	2	CYLINDER ASSEMBLY

Figure 4 – Stepper: mechanism and CW/CCW actuators

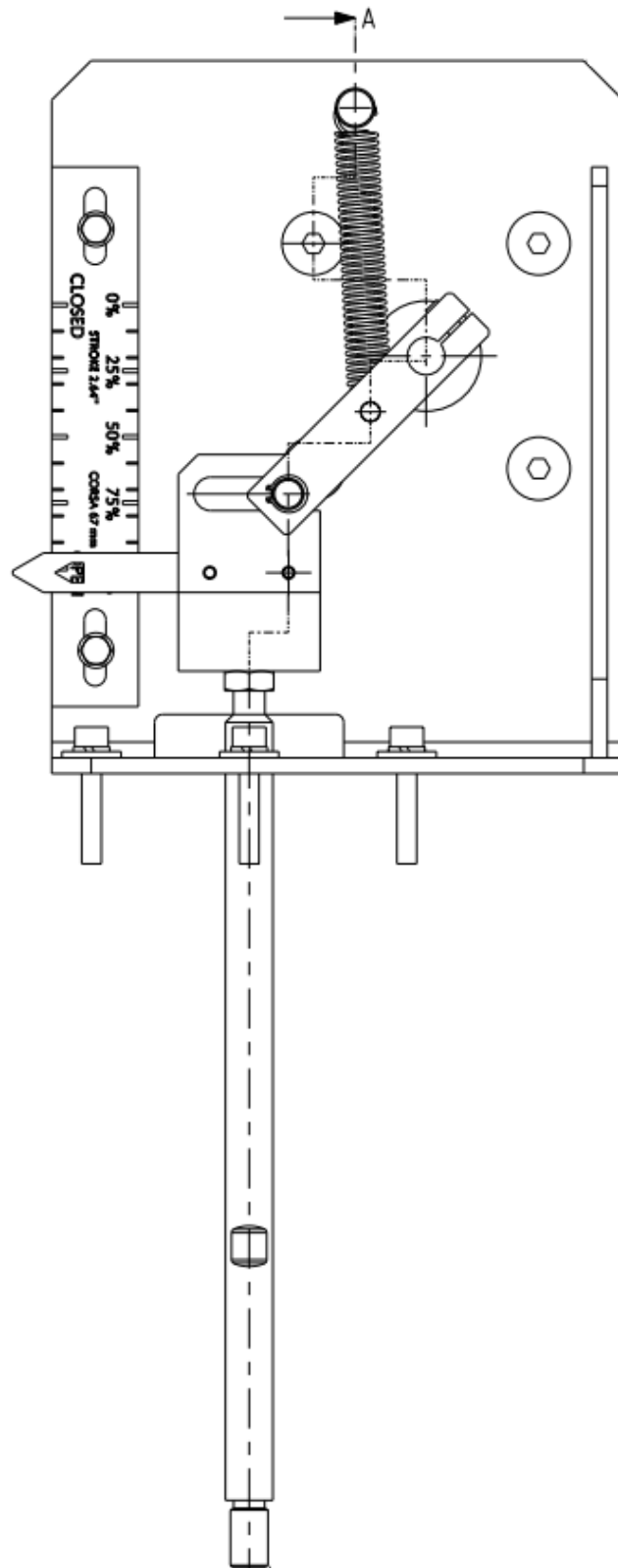



Figure 5 – Position transducer assembly

13 TROUBLESHOOTING

EVENT	POSSIBLE CAUSE	REMEDY
SM valve actuator doesn't move	Lack of hydraulic supply	Check supply line
	Low supply pressure	Adjust supply pressure
	Hydraulic circuit failure	Call STI S.r.l.
	Torque not enough (valve seizing)	Call valve manufacturer
	Torque not enough (wrong actuator sizing)	Call STI S.r.l.
	Damaged actuator internal component	Call STI S.r.l.
Opening/Closing time not satisfy	Hydraulic circuit not suitable	Call STI S.r.l.
	Hydraulic fluid not suitable	Call STI S.r.l.
	Wrong actuator sizing	Call STI S.r.l.
Leakages from hydraulic cylinder	Deterioration and/or damage of gasket	Call STI S.r.l.
	Incorrect tighten of the hydraulic actuator tie rods	Call STI S.r.l.
Leakages from hydraulic circuit	The nuts of pipe fittings are not tighten enough	Tighten the nuts
	An accessory does not work correctly	Call STI S.r.l.

Important 	<p>If another event happens or another possible cause of the above events has been detected, please call STI S.r.l.</p>
---	---

14 SPARE PARTS

Spare parts can be sent to the customer if required. Call STI.

15 DISASSEMBLING

Important 	<p>The disassembling of the main body (box with the hydraulics actuators and the step mechanism inside) is not allowed if it is not authorized by STI.</p>
---	--

16 DECOMMISSIONING

<p>Warning</p> 	<p>The following instructions must be respected:</p> <ul style="list-style-type: none"> - operations must be carried out only by skilled operators; - always wear protective clothing, gloves, and eyewear to prevent personal injury. Check with your process or safety engineer for any additional measures that must be taken to protect against process media.
---	--

<p>Important</p> 	<p>Check local authority regulation before disposal.</p>
---	--

SUBJECT	HAZARDOUS	RECYCABLE	DISPOSAL
Metals	No	Yes	Use licensed recyclers
Plastics	No	Yes	Use specialist recyclers
Rubber (seals, o-rings)	Yes	No	May require special treatment before disposal, use specialist waste disposal companies
Oil and grease	Yes	Yes	May require special treatment before disposal, use specialist waste disposal companies

IMI STI - Headquarters

Via Dei Caravaggi 15
24040 Levate (BG)
Italy

Tel. +39 035 2928.2
Fax +39 035 2928.247

IMI STI – Quarter Turn Division

Via San Francesco 18
29017 Fiorenzuola d'Arda (PC)
Italy

Tel. +39 035 2928.2
Fax +39 0523 1715.295

IMI Critical Engineering

Lakeside, Solihull Parkway
Birmingham Business Park
Birmingham B37 7XZ
United Kingdom

Tel. +44 (0)121 717 3700
Fax +44 (0)121 717 3701

www.stiactuation.com
www.imi-critical.com
imisti.sales@imi-critical.com