

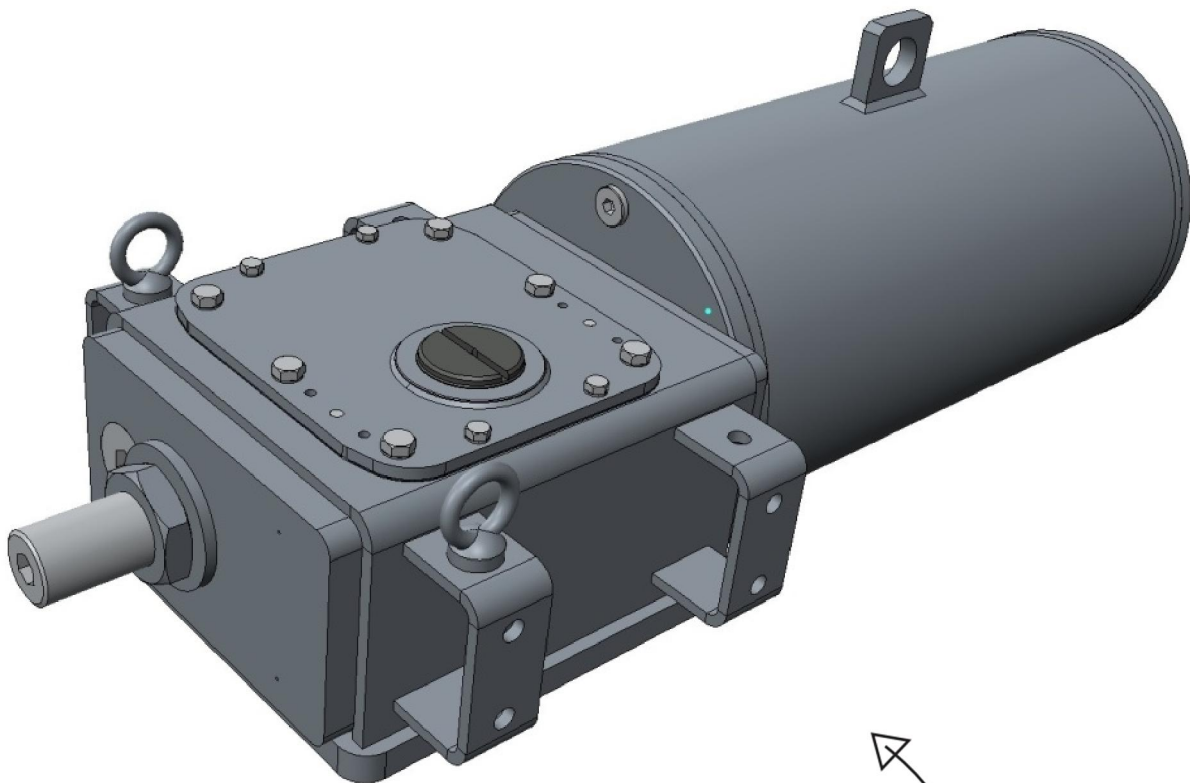

Quarter turn hydraulic actuator RTCHS Series Single acting version type RTCHS

INSTRUCTION MANUAL 5700



Engineering
GREAT Solutions

Date	Revision	Description	Compiled	Approved
10/07/2020	04	Revised Nameplate (Section 4)	G. Alfieri	A. Negri
02/10/2018	03	Revised §1.6 and added §7.3	E. Montagna	F. Tondolo
15/02/2016	02	Revision	M. Bozzarelli	D. Lamoure
02/10/2015	01	Revision	M. Bozzarelli	D. Lamoure
07/04/2014	00	Issue	G. Alfieri	D. Lamoure

STI S.r.l. has taken every care in collecting and verifying the documentation contained in this Instruction Manual. The information herein contained are reserved property of STI S.r.l.

INDEX

1	GENERAL INFORMATION.....	1
1.1	GENERAL WARNINGS.....	1
1.2	GENERALITIES	1
1.3	MANUFACTURER	1
1.4	TERMS AND CONDITIONS	1
1.5	MANUFACTURER’S LIABILITY.....	1
1.6	APPLICABLE STANDARDS AND DIRECTIVES	2
1.6.1	<i>General Standards</i>	2
1.6.2	<i>European Directives (mandatory only for installations in EU Countries)</i>	2
1.7	SYMBOLOLOGY USED	2
1.7.1	<i>Signs of warning</i>	2
1.7.2	<i>Sings of obligation</i>	2
2	DEVICE DESCRIPTION	3
2.1	GENERAL DESCRIPTION	3
2.2	IDENTIFICATION OF THE MAIN PART	3
2.3	ACTUATOR CODING DESCRIPTION.....	4
3	TECHNICAL DATA	5
4	NAMEPLATE	5
5	INSTALLATION.....	6
5.1	TRANSPORT.....	6
5.2	RECEPTION.....	7
5.3	STORAGE	7
5.4	REQUIREMENTS OF STABILITY	7
5.5	INTERFACE DOCUMENT AND DIMENSIONAL DRAWING.....	7
5.6	INSTALLATION	8
5.6.1	<i>Checks to be performed before installation</i>	8
5.6.2	<i>Assembling of the actuator on the valve</i>	8
5.6.3	<i>Hydraulic Connections</i>	9
5.6.4	<i>Electrical Connections (If any)</i>	10
5.6.5	<i>Earting connection</i>	10
5.7	DISASSEMBLING	11
6	OPERATION AND USE.....	12
6.1	OPERATION DESCRIPTION.....	12
6.2	INTENDED USE	12
6.3	REASONABLY FORESEEABLE MISUSE	12
6.4	OPERATING LIMITS.....	13
6.5	RESIDUAL RISKS.....	13
7	INSTRUCTIONS FOR THE OPERATOR.....	13
7.1	START UP	13
7.2	STROKE ADJUSTMENT	14
7.3	MANUAL OVERRIDE	15
8	MAINTENANCE.....	16
8.1	PERIODIC INSPECTIONS.....	16
8.2	SPECIAL MAINTENANCE	17

8.2.1	Scotch yoke Mechanism seals replacement.....	18
8.2.2	Replacement of seals on the hydraulic cylinder.....	20
8.3	REPAIRS	20
8.4	REASSEMBLING	21
8.4.1	Hydraulic cylinder re-assembling.....	21
8.4.2	Actuator re-assembling.....	21
8.5	MECHANISM LUBRICATION	22
8.5.1	Scotch yoke mechanism (see Paragraph 10.1).....	22
8.5.2	Spring cartridge with hydraulic cylinder (see Paragraph 10.2)	22
8.6	HYDRAULIC FLUID	22
9	TROUBLESHOOTING.....	23
10	PARTS LIST GENERAL ASSEMBLY	23
10.1	SCOTCH YOKE MECHANISM.....	24
10.2	SPRING CARTRIDGE WITH HYDRAULIC CYLINDER	25
10.3	STOP SETTING SCREW KIT	26
11	SPARE PARTS.....	26
12	DECOMMISSIONING.....	27
13	DECLARATION OF INCORPORATION	28

1 GENERAL INFORMATION

1.1 General Warnings

Important	<p>This Instruction Manual is an integral part of the machine, it should be carefully read before carrying out any operation and it should be kept for future references.</p> <p>This Instruction Manual covers the RTCHS Series actuators in the base version without any accessories and/or control panel.</p> <p>In case accessories and/or control panel are foreseen mounted on the actuator an additional Section to this Instruction Manual will be attached to the specific actuator.</p> <p>This Instruction Manual is realized in accordance with the Directive 2006/42/CE.</p>
------------------	---



1.2 Generalities

STI S.r.l. actuators are conceived, manufactured and controlled according to the Quality Control System in compliance with EN ISO 9001 International Standard.

1.3 Manufacturer

With respect to Machinery Directive 2006/42/EC the Manufacturer of the described RTCHS actuator series, is **STI S.r.l.** as specified on the machinery label.

STI S.r.l. Via Dei Caravaggi 15
24040 Levate (BG) Italy
Tel. +39 035 2928.2
Fax +39 035 2928.247
imisti.sales@imi-critical.com

1.4 Terms and conditions

STI S.r.l. guarantees each single product to be free from defects and to conform to current goods specifications. The warranty period is one year from the date of installation by the first user, or eighteen months from the date of shipment to the first user, whichever occurs first.

The warranty does not cover special products or components not covered by warranty in their turn by subcontractors. No warranty is given for products which have been subject to improper storage, improper installation, misuse, or corrosion, or which have been modified or repaired by unauthorised personnel. Repair work due to improper use will be charged at standard rates.

1.5 Manufacturer's Liability

STI S.r.l. declines all liability in the event of:

- use of the actuator in contravention of local safety at work legislation
- incorrect installation, disregard or incorrect application of the instructions provided on the actuator nameplate and in this manual
- modifications without STI's authorisation
- work done on the unit by unqualified or unsuitable persons.

1.6 Applicable Standards and Directives

1.6.1 General Standards

- EN ISO 12100:2010: Safety of machinery - General principles for design.
Risk assessment and risk reduction.
- IEC 61508-1/7 (Ed. 2010)
- IEC 61511-1 (Ed. 2016)

1.6.2 European Directives (mandatory only for installations in EU Countries)

- 2006/42/EC Machinery Directive.
- 2014/68/EU Pressure Equipments Directive (PED)
- 2014/35/EU Directive for Low Voltage Equipment (LV)**
- 2014/30/EU Directive relating to the Electromagnetic Compatibility (EMC)**
- 2014/34/EU Directive concerning equipment for use in potentially explosive atmospheres (ATEX)

** Applicable only when electrical control panel is supplied integrate with the actuator

1.7 Symbology Used

1.7.1 Signs of warning

Be careful where these symbols are shown, they indicate a potentially hazardous situation and they warn that if the steps are not properly performed, MAY RESULT CAUSING serious injury, death or long-term risks to the health of exposed persons.



GENERAL DANGER



DANGER POWER SUPPLY



CRUSHING HAZARD

1.7.2 Signs of obligation



General obligation (with the possible supplementary signboard)



Must wear protective clothing.



Obligation to wear protective footwear.



Is required to wear a helmet.



Is required to protect the eyes.



Obligation to protect your hearing.

2 DEVICE DESCRIPTION

2.1 General Description

RTCHS single acting hydraulic actuators, are suitable for the operation of quarter turn valves (ball valves, butterfly valves, plug valves) for ON-OFF and modulating heavy-duty service

The actuator is made up of a weatherproof scotch yoke mechanism transforming the linear movement of the hydraulic cylinder (on closing or opening) or the linear movement due to the force of a spring (in direction opposite to the force of the cylinder) into the rotary movement, which is necessary for valve operation. The travel stroke of the yoke is adjustable between -4 deg / +4 deg at both ends by means of the external mechanical stops arranged into the side-wall of the mechanism body and into the end flange of the hydraulic cylinder. Scotch yoke mechanism centerbody cover is machined to provide the assembly pattern for any required accessories (i.e. positioner, signalling limit switches, position transducer, etc.) by means of proper matching units. The above mentioned accessories are operated by the actuator drive sleeve. Actuator centerbody bottom wall is machined with threaded holes to allow actuator mounting on top of valve top-work either directly or, when required, with the interposition of an adaptor flange or a mounting bracket.

2.2 Identification of the Main Part

The RTCHS actuator is composed by the following main parts:

- 1) Scotch yoke mechanism.
- 2) Spring cartridge with hydraulic cylinder
- 3) Local indicator
- 4) Spring cartridge stop screw assembly
- 5) Housing stop screw assembly

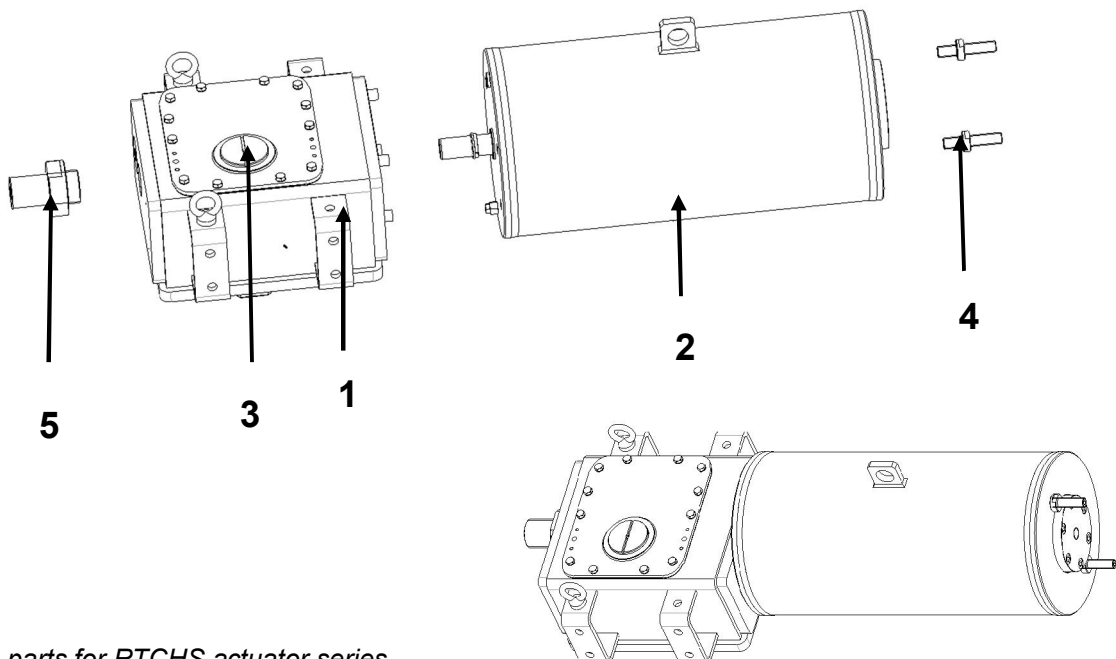
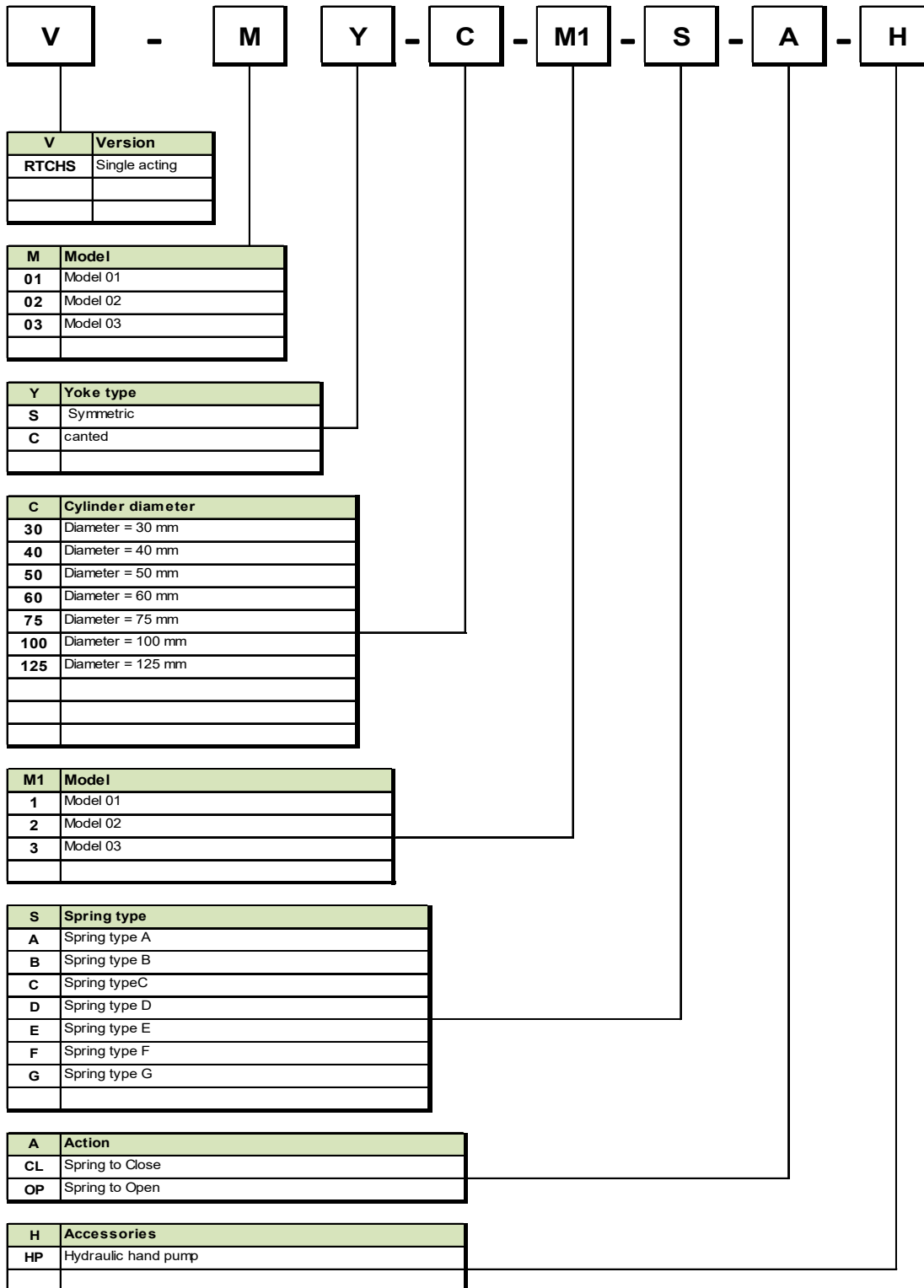

Fig. 1: Main parts for RTCHS actuator series

2.3 Actuator coding description





3 TECHNICAL DATA

DATA	
Supply medium	Hydraulic fluid (see Section 8.6)
Operating temperature	General applications (outside EU Countries): Standard: -30°C +100°C Optional: -60°C +100°C (*) PED applications (within EU Countries): Standard: -20°C +100°C Optional: -50°C +100°C (*) (*) for SIL applications T° amb. min ≥ -40°C
Cylinder design pressures	103, 207 or 345 bar
Operating pressure range	Data are available on actuator nameplate depending on customer requirements and specifications
Max Output torque	RTCHS 01 Series up to 1.100 Nm RTCHS 02 Series up to 3.000 Nm RTCHS 03 Series up to 6.000 Nm
Design life	30 years
Applications	On-Off Modulating service (on request)

The nameplate fastened on the actuator contains the main actuator operating condition.
 It is forbidden to modify the information and the marks without previous written authorization by STI S.r.l.

4 NAMEPLATE

 STI s.r.l. Via Dei Caravaggi 15 - 24040 LEVATE (BG)-ITALY www.imi-critical.com - FAX +39 035 2928247			
 II 2 GD		Ref. INERIS <input type="text"/>	
Ex h II <input type="checkbox"/> T4 Gb / Ex h III C T135°C Db		Certificate IECEx INE 19.0024	
Order	<input type="text"/>	Serial N°	<input type="text"/>
Model	<input type="text"/>	Year	<input type="text"/>
Rated Torque	<input type="text"/> Nm	Max. allowable Pressure	<input type="text"/> bar
Pressure Range	min <input type="text"/> / max <input type="text"/> bar	Fluid	<input type="text"/>
Temp. Range	min <input type="text"/> / max <input type="text"/> °C	Valve TAG	<input type="text"/>
Degree of Protection IP66/67H according to IEC/EN 60529			

5 INSTALLATION



Important: Not performing the following procedures will invalidate the product guarantee.

5.1 Transport



Important: The lifting and handling should be made by qualified staff and in compliance with the laws and provisions in force.



Warning: Lift the actuator as shown in Fig.2.
The fastening points are appropriate for the lifting of the actuator alone and not for the valve + actuator assembly.



Warning: Avoid that during the handling, the actuator passes above the staff.
The actuator should be handled with appropriate lifting means.
The weight is reported on the delivery bill and on overall-dimensions drawings furnished with the documents accompanying the actuator.
For base actuator dimensions and weights please consult www.stiactuation.com

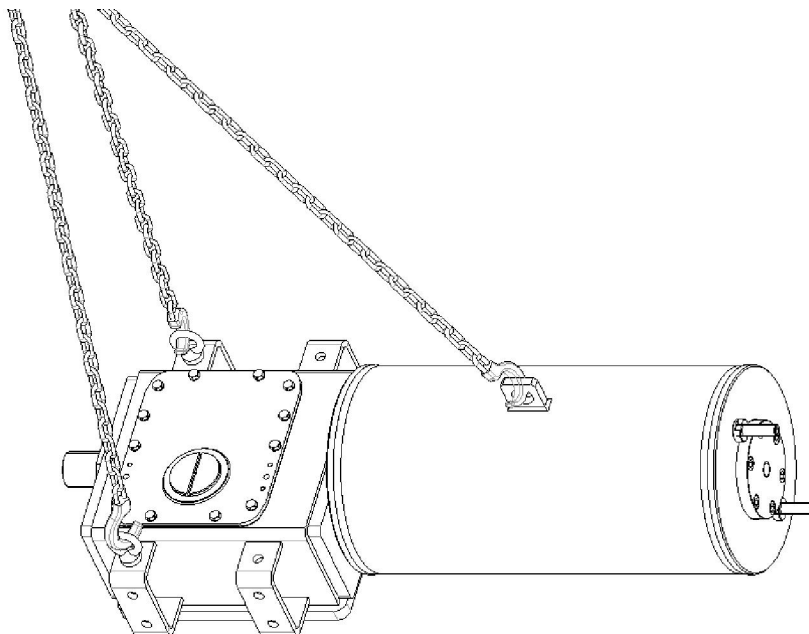

Fig. 2 – Lifting points for RTCHS actuator series

5.2 Reception

- Check that the model, the serial number of the actuator and the technical data reported on the nameplate correspond with those of order confirmation (Sect. 4).
- Check that the actuator is equipped with the fittings as provided for by order confirmation.
- Check that the actuator was not damaged during transportation: if necessary renovate the painting according to the specification reported on the order confirmation.
- If the actuator is received already assembled with the valve, its settings have already been made at the factory. If the actuator is delivered separately from the valve, it is necessary to check, and, if required, to adjust, the settings of the mechanical stops (Sect. 6.2).

5.3 Storage

All the actuators RTCHS leave the factory in perfect condition. Performances of each unit are guaranteed by individual test and data reported on a specific test certificate issued for each unit.

In order to maintain these characteristics until the RTCHS actuator is installed on site, proper attention must be observed for preservation during the storage period.

If the actuator needs storage, before installation follow these steps:

- Place it on a wood surface pallet or on metallic support, so that they are not in direct contact with the ground, in order not to deteriorate the area of valve coupling, later it must be packed with appropriate covering.
- Make sure that plastic plugs are present on the hydraulic and electrical connections (if present).
- Check that the limit switch box (if any) is properly closed.

If the storage is long-term or outdoor:

- Keep the actuator protected from direct weather conditions.
- Replace plastic plugs of hydraulic and electrical connections (if any) with metal plugs that guarantee perfect tightness.
- Coat with oil, grease or protection disc, the valve coupling area.
- Periodically operate the actuator (Sect.5).

5.4 Requirements of Stability

- Conditions in which the machinery meets the requirement of stability during use, transportation, assembly, dismantling when out of service, testing or foreseeable breakdowns, are shown in Fig.2.
- The actuator must be put, with extreme caution, in a right position on a plane surface and with adapted capacity to the load to support.
- Do not use actuator eye bolts lifting of valve-actuator package.
- Concerning the requirement of stability during installation and disassembling it 's possible to refer to the next chapters 5.6 and 5.7.

5.5 Interface document and dimensional drawing

- Hydraulic diagrams, wiring diagrams and dimensional drawing are furnished with document accompanying the actuator.

5.6 Installation

	<p>Warning: Before proceeding with any Installation the following instructions must be respected:</p> <ul style="list-style-type: none"> - Always wear protective clothing, gloves, and eyewear to prevent personal injury. - Use the lifting point foreseen on the actuator to move the actuator: if different instructions are not well specified the lifting points foreseen on the actuator must be used only to move the actuator. - Check with your process or safety engineer for any additional measures that must be taken to protect against process media.
---	---

5.6.1 Checks to be performed before installation

If the RTCHS actuator is purchased separately, proceed as follows before assembling it onto the valve:

- 1) Check that the coupling dimensions of the actuator/coupling block flange and stem meet the specified coupling dimensions.
- 2) Prepare the necessary tools for the assembly and setting of the unit.
- 3) Check that the outer surface of the actuator is free from dust and dirt.
- 4) Clean the actuator flange and remove anything that might prevent a perfect adherence to the actuator/coupling block flange and joint especially all traces of grease.

5.6.2 Assembling of the actuator on the valve

The actuator can be assembled on top of the valve flange either by using the actuator-housing flange with threaded holes, or by the interposition of a proper mounting hardware.

The actuator drive sleeve is generally connected to the valve stem by an insert bush or a stem extension. The assembly position of the actuator, with reference to the valve, must comply with the plant requirements (cylinder axis parallel or perpendicular to the pipeline axis).

To assemble the actuator onto the valve proceeds as follows:

- Move the valve and the actuator to their fails position
- If an insert bush or stem extension for the connection to the valve is supplied separately, assemble it onto the valve stem and fasten it by tightening the proper stop dowels.
- Connect a sling to the support points of the actuator and lift it: make sure the sling is suitable for the actuator weight
- Lower the actuator onto the valve in such a way that the insert bush, assembled on the valve stem, enters the actuator drive sleeve. This coupling must take place without forcing and only with the weight of the actuator.
- When the insert bush has entered the actuator drive sleeve, check the holes / pin of the valve flange meet the actuator holes and pin, otherwise rotate the mounting bracket to obtain a right assembling.

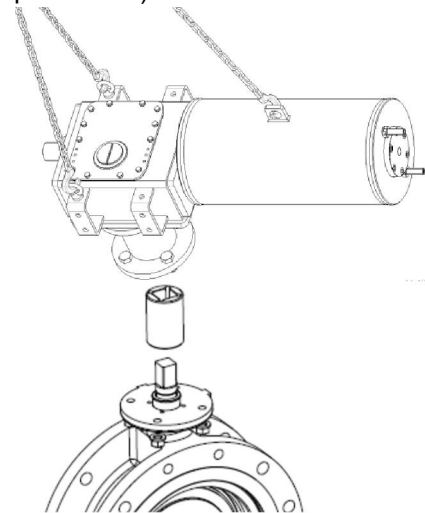

Fig. 3 – Assembling of the actuator on the valve



	<p>Important</p> <p>To guarantee the correct transmission of torque from the actuator to valve stem without phenomena of slip it is important to remove any trace of oil and/or grease from the mating surfaces of valve and actuator or bracket and tighten the nuts fixing the bolts with the torque specified into the following Table 1</p>
---	--

Table 1

Threading	Tightening torque (Nm)	Threading	Tightening torque (Nm)
M8	20	M24	550
M10	40	M27	700
M12	70	M30	800
M14	110	M33	1200
M16	180	M36	1800
M20	340		

The torque values in Table 1 have been calculated considering the materials ASTM A320 grade L7/ASTM A193 grade B7 for screws or tie rods and ASTM A194 grade 4 for the nuts.
 Alternative bolting permitted i.e. ASTM A193 B8M (or B8M3) for tie rods and ASTM A194 Gr.8M for the nuts, provided that yield strength of screws or tie rods is over than 450 Mpa.

5.6.3 Hydraulic Connections

	<p>Warning: Check that the values of hydraulic supply available are compatible with those reported on the identification plate of the actuator.</p> <p>Warning: Use pipes and connections appropriate as for type, material and dimensions.</p> <p>Warning: The connection should be made by qualified staff.</p>
---	--

- Properly deburr the ends of rigid pipes.
- Properly clean the interior of pipes sending through them plenty of the supply fluid used in the system.
- Mould and fasten the connection pipes so that no irregular strains at entries or loosening of threaded connections occur.
- Make the connections according to the operating diagram.
- Check the absence of leakages from hydraulic connections. If necessary tighten the nuts of the pipe-fittings.

5.6.4 *Electrical Connections (If any)*

Warning	Before carrying out electrical connections, switch off any power and control lines. Use components appropriate as for type, material and dimensions. The connections should be made by qualified staff.
----------------	---



- Introduce connection cables.
- Make the connections in compliance with applicable wiring diagrams on the documentation supplied.
- Screw the cable gland.
- Replace the plastic plugs of unused entries with metal plugs.

5.6.5 *Earting connection*

If the earthing connection is not guaranteed through mechanical parts where actuator is mounted, it is necessary ensure a directly earthing connection on provided point of actuator.

5.7 Disassembling

<p>Warning</p> 	<p>Before starting the disassembly operations it is mandatory to disconnect the hydraulic power and to exhaust the cylinder and any other pressure retaining component mounted on the actuator.</p> <p>Before removing the screws between actuator and valve or adaptor flange or mounting bracket, the actuator should be connected with appropriate lifting means. Lift the actuator as shown in Fig.3. The lifting points are appropriate for handling the actuator alone and <u>not for the valve + actuator assembly.</u></p> <p>During the disassembling take care that the mounting coupling block is fix on the valve stem to avoid any dangerous situation.</p>
---	---

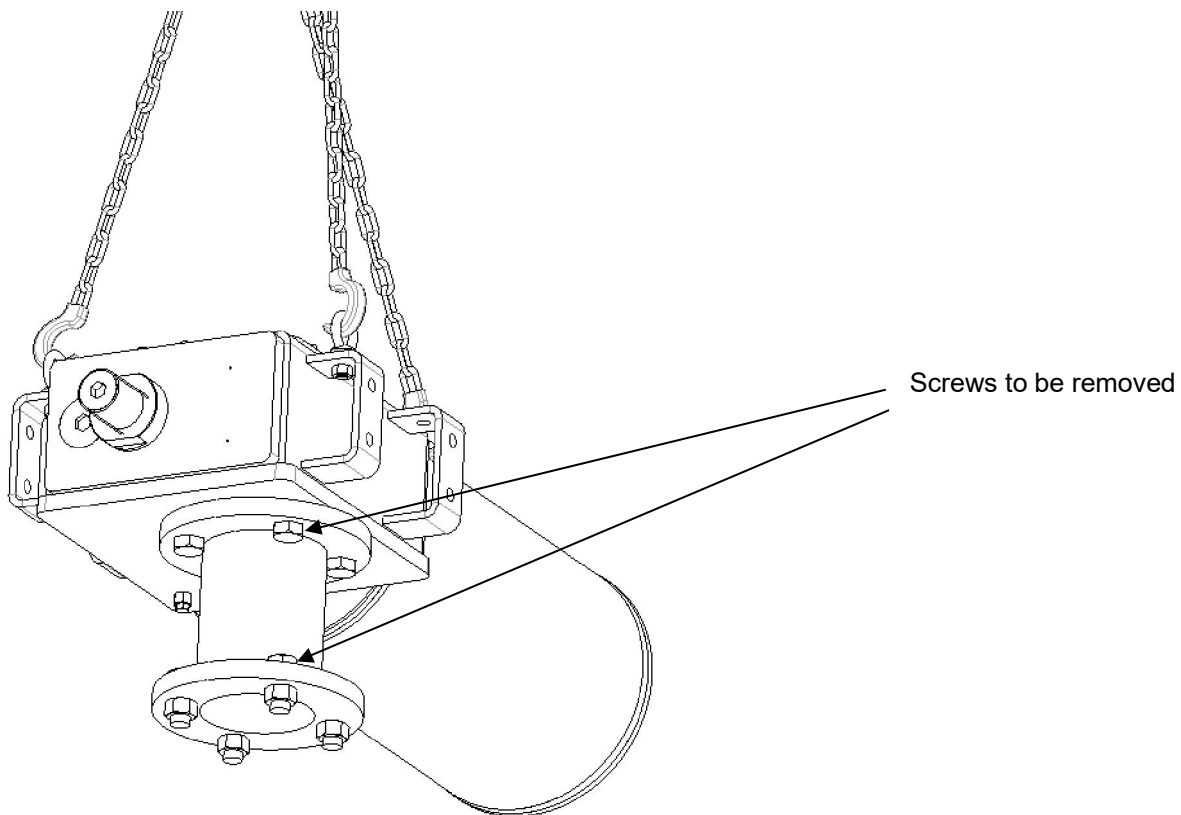

Fig. 4 – Disassembling of the actuator

6 OPERATION AND USE

6.1 Operation description

The RTCHS series is a single acting hydraulic actuator designed for on-off and control service and is applicable over a wide range of pressure, temperatures and environments.

The scotch yoke mechanism converts the linear motion of hydraulic piston or spring into valve rotation by the actuator shaft. The symmetric scotch yoke mechanism generates high torque at start (0° degree) and the end (90° degree) of the valve stroke, typically valve torque figure of ball valve. The canted scotch yoke mechanism generates very high torque when valve is closed, typically valve torque figure of butterfly valve.

6.2 Intended use

The machinery covered in this Instruction Manual is single acting hydraulic actuator RTCHS series designed to operate a quarter turn industrial valve (ball valves, butterfly valves, plug valves, dampers,...) for ON-OFF or modulating heavy duty service.

This RTCHS actuator Series is produced by **STI srl** [Manufacturer] and identified by a label with a product designation code. **STI srl** will not be liable for any possible damage or physical injury resulting from use in other than the designated applications or by lack of care during installation, operation, adjustment and maintenance of the machine. Such risks lie entirely with the user. Depending on the specific working conditions, additional precautions may be requested. Considering that **STI srl** has no direct control over particular applications, operation or maintenance conditions, it is the operator's responsibility to comply with all applicable safety rules. Please inform **STI srl** urgently if you face unsafe situations not described in this Instruction Manual. It is the sole responsibility of the operator to ensure that the local health and safety regulations are adhered to.

RTCHS actuator Series is designed in accordance with the applicable International Rules and Specifications, but the following Regulations must be observed in any case:

- the general and safety regulations
- the plant specific regulations and requirements
- the proper use of personal and protective devices (glasses, clothing, gloves, etc)
- the proper use of tools, lifting and transport equipment.

<p>Warning</p> 	<p>It is severely forbidden to use the RTCHS actuators Series for purpose or application other than those for which it was designed and here above specified</p>
---	---

6.3 Reasonably foreseeable misuse

A short list of reasonably foreseeable misuse:

- Installation in ambient with not planned conditions: i.e. climatic conditions different from the specified conditions;
- Insert incorrect fluid into the system;
- Supply pressure out of required range;
- Lifting of the actuator with valve through eye bolts.

6.4 Operating limits

Operating conditions are described in paragraph 3, the nameplate fastened on the actuator contains the main actuator operating condition for the specified application.

<p>Warning</p> 	<p>It is severely forbidden to use the actuator under conditions other than those provided on the nameplate.</p>
---	--

6.5 Residual Risks

<p>Warning</p> 	<p>The actuator has parts under pressure. Use the due caution. Use individual protections provided for by the laws and provisions in force.</p>
---	---

- Risk due to movements of loads during load displacements, assemblage and maintenance servicing.
- Electrical risk due to an incorrect application of the instruction.
- Crushing during assemblage and maintenance servicing.
- Extreme metal temperature at high (over than 80°C) or very low values as consequence of ambient temperature as to be considered as a risk of person injury in case of contact.

7 Instructions for the operator

7.1 Start Up

During the start-up of the actuator, proceed as follows:

- Check that the pressure and quality of the hydraulic fluid (filtering degree,...) are as prescribed.
- Check that the feed voltage values of the electric components (solenoid valve coils, micro-switches, pressure switches, etc.) are as prescribed.
- Check that the actuator controls work properly (remote control, local control, emergency controls, etc.)
- Check that the required remote signals (valve position, air pressure, etc.) are correct.
- Check that the setting of the components of the actuator control unit (pressure regulator, pressure switches, flow control valves, etc.) meet the plant requirements.
- Check that there are not leak in the hydraulic connections. If necessary tighten the nuts of the pipe fittings.
- Remove all rust and, in accordance with the applicable painting specifications, repair paint-coat that has been damaged during transport, storage or assembly.

7.2 Stroke adjustment

Important



It is assumed that the following instructions are executed in the workshop using air as the power fluid.
Instructions are applicable when the actuator is already installed on the valve.

It is important that the mechanical stops of the actuator (and not those of the valve) stop the rotary stroke at both extreme valve positions (fully open and fully closed), except when different configuration is required by the type of the valve (i.e.: eccentric butterfly valves,...).

The setting of the open/closed valve position is performed by adjusting the setting screws foreseen into the end flange of the spring cartridge (see Fig.5) and on the side wall of the scotch yoke mechanism (see Fig. 6) following the instructions listed here below.

For the adjustment of the travel stop screws in the end flange of the spring cartridge proceed as follows (Fig.5):

- Unscrew the nuts (2.4) from the travel stop (2.9) and remove the sealing washer (2.8).
- Unscrew completely the travel stops (2.9) and adjust the valve stroke to the right position.
- After detected the right position, tight both the travel stops (2.9) against the internal spring holder.
- Fix the sealing washers (2.8) keeping the travel stops locked with proper nut (2.4).

For the open position adjustment on the travel stop located into the actuator centerbody side-wall proceed as follows (Fig.6):

- Loosen the nut (3.1) from the travel stop screw (3.2) keeping the latter locked with a proper wrench key.
- Adjust the valve stroke screw/unscrew the travel stop screw (3.2)
- After detected the right position, tight the nut (3.1) keeping the travel stop screw (3.2) locked.

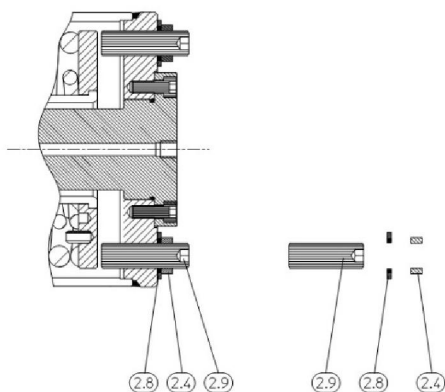

Fig. 5 – Stroke adjustment

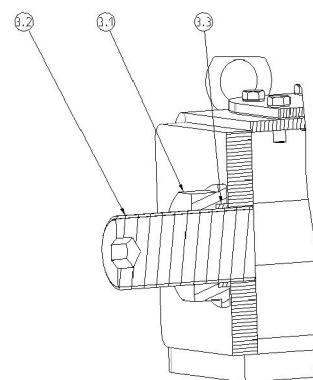

Fig. 6 – Stroke adjustment



Operate the actuator with hydraulic supply to check that the actuator moves properly and that there are no leakages

7.3 Manual Override

When requested, a manual override to move the actuator in case of lack of pneumatic pressure is supplied as an integral part of the actuator itself.

For the single acting actuators Series RTCS an hydraulic manual override is foreseen (see picture 9).

Important	Position of the valve and position of the manual override in relation to the actuator availability MUST be always known.
	The following description provide the information to enable the operator to know the position of the manual override.
	Position of the valve is provided by the local indicator described at paragraph 2.2 item 3).

Indication of position of the manual override with respect to the safety

For this type of Manual Override a specific **Instruction Manual 2094** is available.

By means a selector lever it is possible to select LOCAL or REMOTE operation. (see Figure 9)

When lever of the local selector is in LOCAL position, identified by a specific label fixed on device, the manual override HP is engaged, consequently the actuator cannot be operated by remote inhibiting its safety function.

To restore the automatic function the selector lever must be rotated 90° clockwise towards the position identified by the label REMOTE.

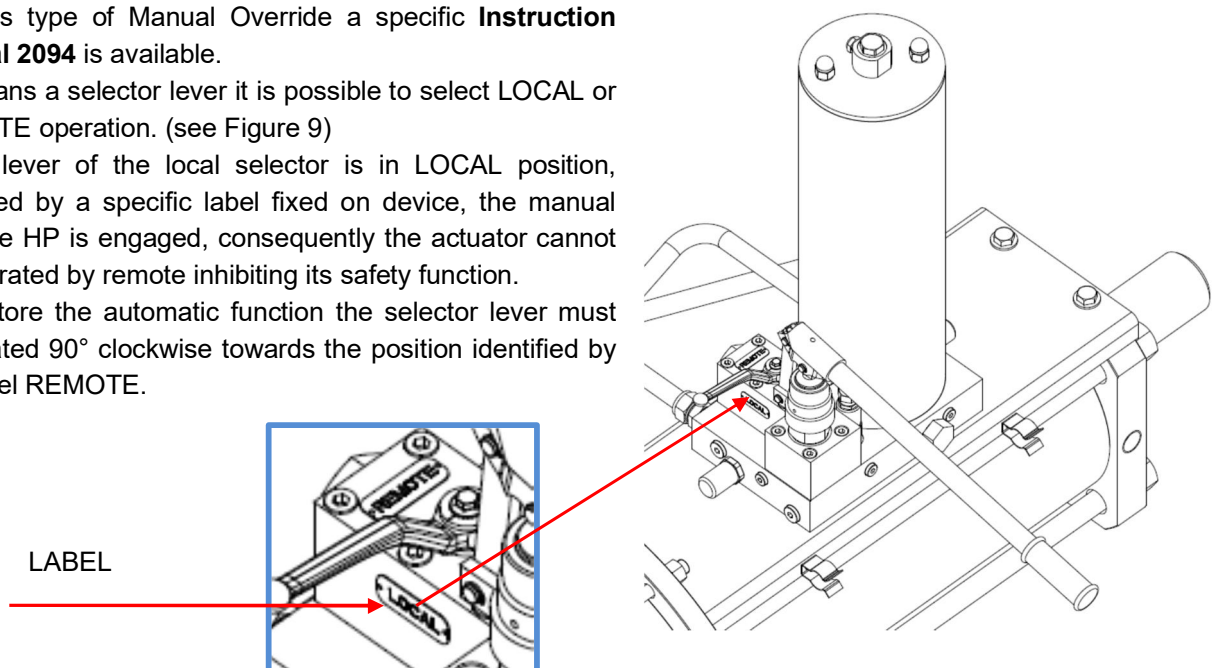

Fig. 9 – HP device

8 MAINTENANCE

8.1 Periodic Inspections

Inspect the general conditions at regular intervals: recommended frequency of inspection is one time every two years but this frequency could be changed depending on the installation and working conditions.

- Check that the actuator operates the valve correctly and with the required operating times. If the actuator operation is very infrequent, carry out a few opening and closing operations with all the existing controls (remote control, local control, emergency controls, etc.), if this is allowed by the conditions of the plant.
- Check that the signals to the remote control desk are correct.
- Check that the hydraulic supply pressure value is within the required range.
- If there is an air filter on the actuator, bleed the condense water accumulated in the cup by opening the drain cock. Disassemble the cup periodically and wash it with soap and water; disassemble the filter: if this is made up of a sintered cartridge, wash it with nitrate solvent and blow through with air. If the filter is made of cellulose, it must be replaced when clogged.
- Check that the external components of the actuator are in good conditions.
- Check all the paint-coat of the actuator. If some areas are damaged, repair the paint-coat according to the applicable specification.
- Check that there is no leak in the hydraulic connections. If necessary tighten the nuts of the pipe-fittings.





Warning: Take care that a build-up of dust or dirt on the actuator can inhibit cooling and contribute to increase surface temperature. The user should plan and provide for a periodic cleaning/maintenance program that will maintain the external surface of the actuator free from excessive layer of dust.



Important: Use only STI: original spare parts. STI cannot accept responsibility for any damages that occur from using spare parts or fastening materials from other manufacturers.
If STI products (i.e. gasket, o-ring etc) have been on store for longer periods check these for corrosion or deterioration before using these products.

8.2 Special maintenance

Under normal condition the actuator don't need special maintenance. If there are leaks in the hydraulic cylinder or a malfunction in the mechanical components, or in case of scheduled preventive maintenance, the actuator must be disassembled (sec. 5.4) and seals must be replaced with reference to the attached sectional drawing and adopting the following procedures (Sec. 7.3).

	<p>Warning: Before proceeding with any maintenance operation the following instructions must be respected:</p> <ul style="list-style-type: none"> - Disconnect any operating lines providing air pressure, electric power, or a control signal to the actuator. Be sure the actuator cannot suddenly open or close the valve - Close the hydraulic feed line and exhaust the pressure from the actuator cylinder and from the control unit, to ensure safety of maintenance staff.
	<p>Important: Before performing any maintenance operations:</p> <ul style="list-style-type: none"> - Use always wear protective gloves, clothing, and eyewear when performing any maintenance operations.

<p>Warning</p>		<p>To release spring tension, the fluid inside the cylinder must be completely exhausted through the connection located on the end flange of the spring cartridge.</p>
-----------------------	---	--

If the actuator need to be disassembled from the valve on site, remove the screws fixing between the actuator and the main valve or adaptor flange or mounting bracket (see Section 5.4 of this Manual).

8.2.1 Scotch yoke Mechanism seals replacement

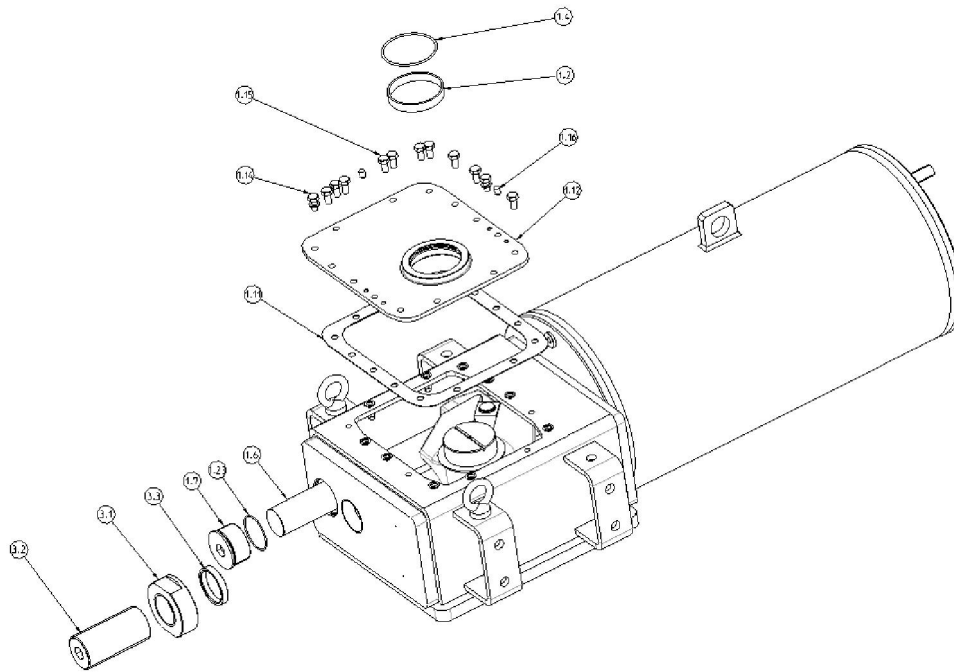

Fig. 7 – Scotch yoke mechanism seals replacement

To change the Seals of stopper on the housing is necessary to remove the nut (3.1) and washer (3.3). Once perform these actions unscrew totally the stop screw (3.2), disassemble the plug (1.7) so that replace the o-ring (1.23).

To replace the cover gasket (1.11) under the cover (1.12), you should remove it by removing all the screws and dowel pins (1.14, 1.15 and 1.16), before replace cover gasket clean the housing and cover. After removing the cover you may replace the o-ring (1.4).

Clean the seal groove carefully and lubricate it with protective oil or grease film.

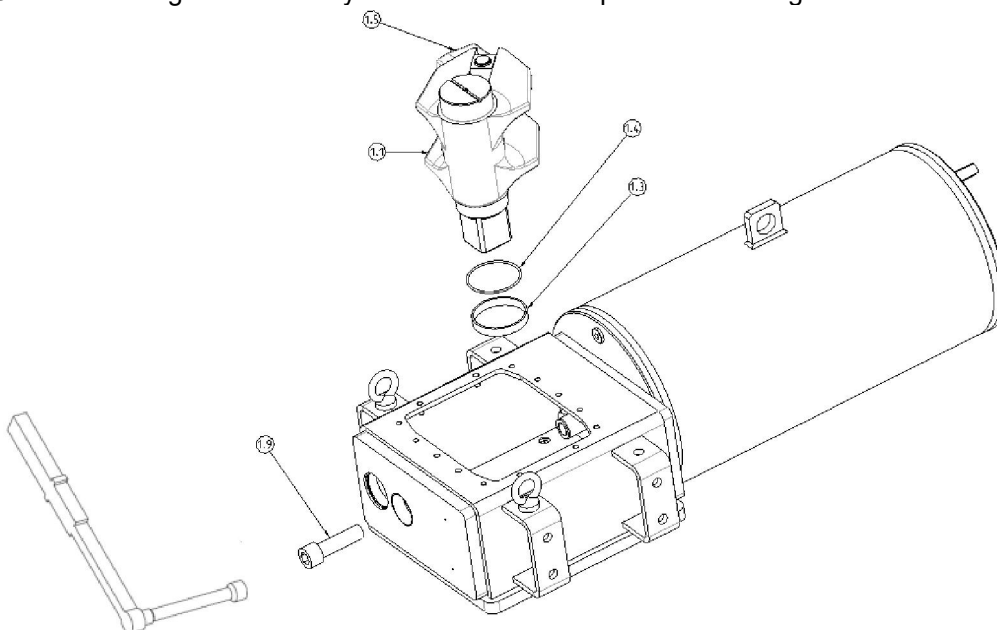

Fig. 8 – Scotch yoke mechanism seals replacement.

In the case of single-acting actuator, make sure the piston is against the stopper. Remove the fixing screw (1.9) of the guide block (1.5) on the piston rod using a wrench with an extension. Rotated scotch yoke and guide block in order to be able to extract from the opening. At this point you can remove the bushing (1.3) and the O-ring (1.4)
Clean the seal groove carefully and lubricate it with protective oil or grease film.

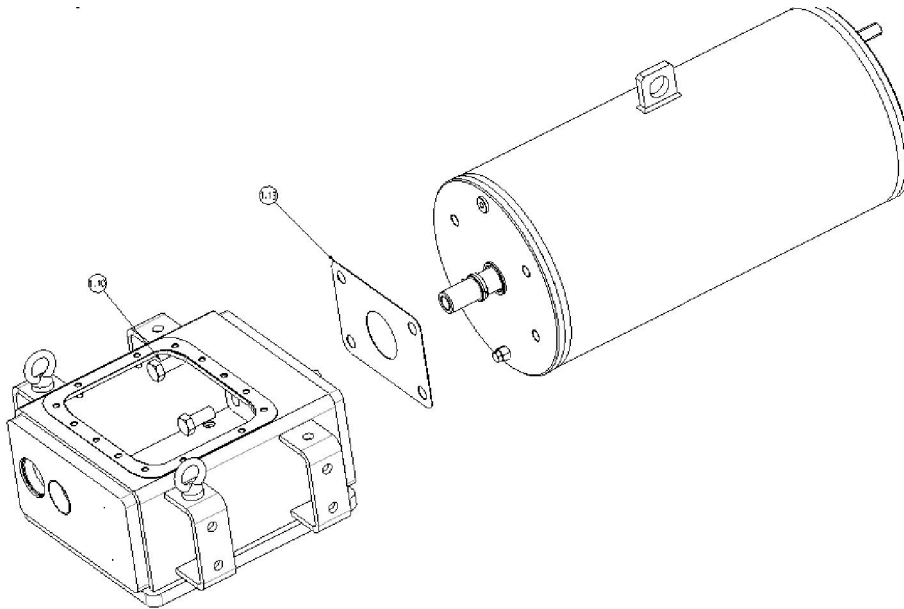

Fig. 9 – Scotch yoke mechanism seals replacement

To replace the gasket (1.13) between cylinder and actuator is necessary to remove the screws (1.10) and disassemble the hydraulic cylinder.

8.2.2 Replacement of seals on the hydraulic cylinder

Warning



Before starting with the disassembling of the hydraulic parts be sure that the power fluid is completely exhausted and the end stoppers (item 9 on Fig. 10) are fully engaged and blocked against the spring holder

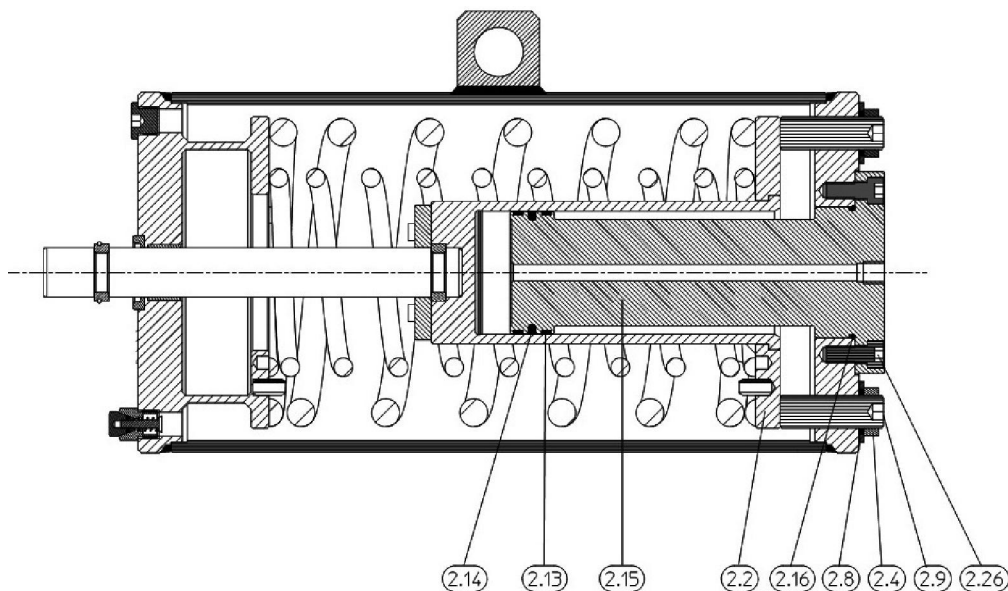

Fig. 10 – Hydraulic cylinder seals replacement of single acting actuator

Unscrew the screws (2.26) and completely remove from the spring cartridge the piston (2.15).

Replace the seals (2.16) and (2.14) from the piston.

Replace the sliding guides (2.13).

Before re-assemble clean all seal grooves carefully and lubricate them with protective oil or grease film.

Check that the hydraulic cylinder is proper assembled before carry out any other maintenance operation.

8.3 Repairs

When needed, repair must only be carried out with Manufacturer's original spare parts.

Original spare parts must be required to the Manufacturer with reference to the item numbers shown in the next Section 7.

To ensure that right spare is provided, **serial number** printed on the RTCHS series label must be specified when spares are ordered.

8.4 Reassembling

8.4.1 Hydraulic cylinder re-assembly.

Carefully clean the inside of the tube and check that the entire surface, particularly that of the bevels, is not damaged. Lubricate with a protective oil or grease film the tube internal surface and the bevels at the ends. Lubricate every seal grooves taking care there are not damages on seal surfaces.

Slide the piston onto the spring cartridge taking care not to damage the seal rings: the tube bevel has to smoothly compress the piston seal ring; take care also not to damage the head flange O-ring.

Assemble the screws (please refer to cylinder sectional drawing) onto the end flange of spring cartridge.

Tighten the screws following the recommended torque (sec. 5.6.2), alternating between opposite corners.

8.4.2 Actuator re-assembly

Assemble the hydraulic cylinder to the housing tightening, with recommended torque table, the screw between cylinder and housing. Replace o-ring at the bottom of the housing making attention there are not dirty or damage on the seal surface, put the bushing on its seat. Re-assemble scotch yoke and guiding block, make a generous coating of grease on the contact surfaces of yoke and the bushings, assemble the guide bar and close the assemble the plug to close the guide bar. Tighten the screw between cylinder piston rod and guiding block, with recommended torque, using a wrench. Assemble the o-ring, the cover gasket and the cover with all screw.

Recommended tighten torque Table in Section 5.6.2.

Important



After maintenance operations carry out a few actuator operations to check that its STROKING is regular and that there is no leak through the seals and fittings.

8.5 Mechanism Lubrication

RTCHS actuators do not need lubrication during their life.

However, if during special maintenance operations it is necessary to replace the grease, the following products are recommended.

8.5.1 Scotch yoke mechanism (see Paragraph 10.1)

Molykote G-4700 grease produced by Dow Corning

8.5.2 Spring cartridge with hydraulic cylinder (see Paragraph 10.2)

Rheosil 500 F oil produced by Nye Lubricant, Inc.

	<p>Important</p> <p>The above products cover the full range of temperatures from -60°C up to +100°C.</p> <p>Equivalent products can be used provided that they have the same characteristics and the same range of compatibility with elastomeric and plastic components.</p>
--	--

8.6 Hydraulic Fluid

Recommended hydraulic fluids to operate the RTCHS actuators are listed here below.

Equivalent fluids can be used provided they have the same characteristics of the below recommended fluids.

AGIP ARNICA 22	AEROSHELL Fluid 41
To be used in standard temperature conditions (-20°C/+100°C)	To be used in low temperature conditions (-60°C/+100°C)
Manufacturer: Agip	Manufacturer: Shell
Viscosity at 40°C: 22 cSt	Viscosity at 40°C: 14,1 cSt
Viscosity at 100°C: 4,94 cSt	Viscosity at 100°C: 5,30 cSt
Viscosity Index: 157	Viscosity Index: > 200
Flash point COC: 192 °C	Flash point COC: 105 °C
Pour Point: < -39 °C	Pour Point: < -60 °C
Mass density at 15°C: 0,857 Kg/l	Mass density at 15°C: 0,87 Kg/l

9 TROUBLESHOOTING

Event	Possible cause	Remedy
Actuator doesn't work properly	Lack of hydraulic supply	Check supply line
	Defective main valve	Consult valve manufacturer documentation
	Failure of the control group	Call STI s.r.l. - Customer Care Dept.
Actuator too slow	Low supply pressure	Adjust supply pressure
	Incorrect speed control settings	Adjust speed controls to increase flow
	Exhaust port blocked	Remove and clean the exhaust port silencers and replace
	Wear of the main valve	Consult valve manufacturer documentation
Actuator too fast	High supply pressure	Reset
	Incorrect speed control settings	Adjust speed controls to decrease flow
Leakages on hydraulic circuits	Deterioration and/or damage to gaskets and or loosed fittings	Tightens loosed fittings Call STI s.r.l. - Customer Care Dept..
	Damage to fittings	Call STI s.r.l. - Customer Care Dept.
Leakages on hydraulic cylinder	Damage to seals	Replace cylinder seals
Incorrect position of the valve	Wrong adjustment of mechanical stops	Re-adjust setting
	Wrong electric limit switches indication.	Re-adjust setting

10 PARTS LIST GENERAL ASSEMBLY

This section includes the drawings and parts lists of each component and subassembly of RTQH series.

Important 	<p>When ordering spare parts, please indicate the serial number embossed on the actuator nameplate.</p> <p>Recommended spare parts for special or scheduled preventive maintenance are identified by index # on the next tables.</p> <p>When ordering any other part, please refer to the part item listed on the next tables</p>
---	--

10.1 Scotch yoke mechanism

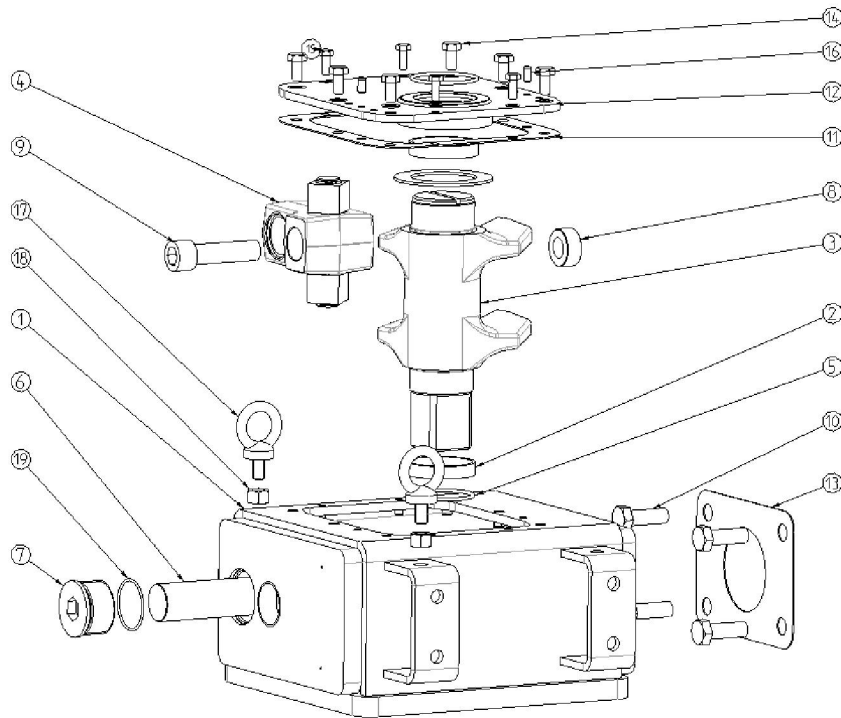

Scotch yoke mechanism part list

Item	Description	Qty	Material	Spare Parts
1	Scotch yoke housing	1	Carbon steel	
2	Bushing	2	Steel/Bronze/PTFE	
3	Scotch yoke	1	Alloy steel	
4	Guide block assembly	1	Carbon steel + Bronze	
5	O-ring	2	NBR (*)	#
6	Guide bar	1	Alloy steel	
7	Plug	1	Carbon steel	
8	Spacer	1	Carbon steel	
9	Screw	1	Carbon steel	
10	Screw	4	Carbon steel	
11	Cover gasket	1	Fiber	#
12	Cover	1	Carbon steel	
13	Gasket	1	Fiber	#
14	Screw	6	Carbon steel	
15	Screw	4	Carbon steel	
16	Cylindrical pin	2	Carbon steel	
17	Lifting eyelet	2	Carbon steel	
18	Nut	2	Carbon steel	
19	O-ring	1	NBR (*)	#

(*) NBR standard material for temperature range from -30°C up to +100°C.

10.2 Spring cartridge with hydraulic cylinder

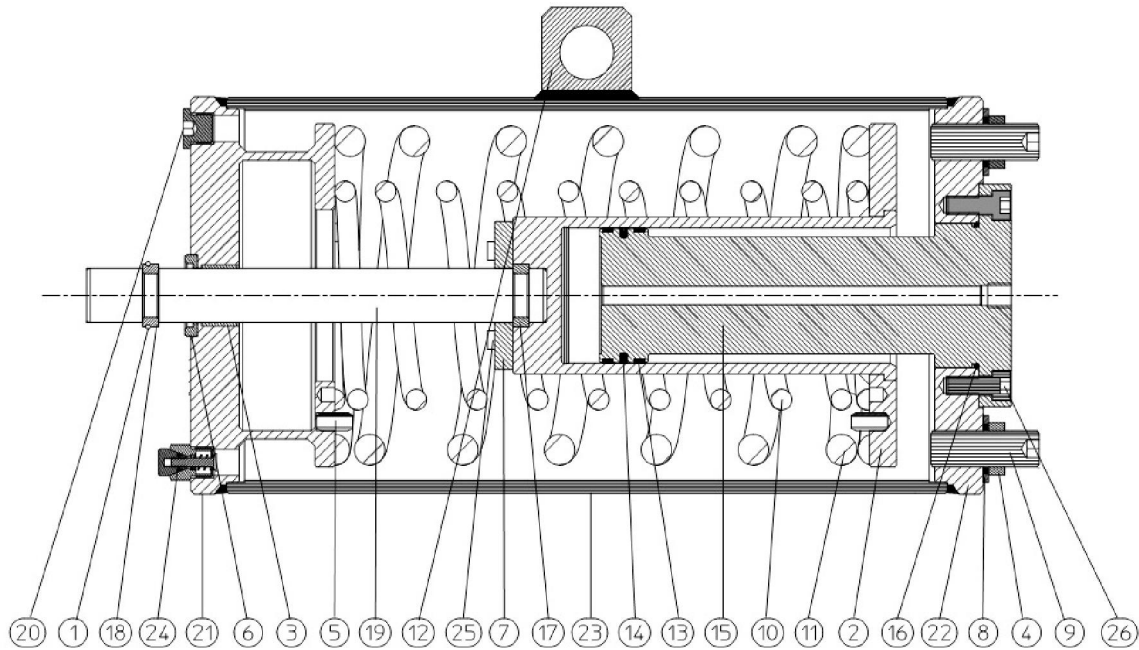

Spring cartridge with hydraulic cylinder part list

Item	Description	Qty	Material	Spare Parts
1	Elastic ring	1	Carbon steel	
2	Cylinder tube/spring holder	1	Carbon steel	
3	Bushing	1	Steel/bronze/PTFE	
4	Nut	1	Carbon steel	
5	Elastic pin	4	Carbon steel	
6	Limiting flange	1	Carbon steel	
7	Rod flange	1	Carbon steel	
8	Sealing washer	2	Carbon steel+PTFE	#
9	Stop screw	2	Carbon steel	
10	Internal spring	1	Alloy steel	
11	External spring	1	Alloy steel	
12	Lifting eyelet	1	Carbon steel	
13	Sliding guide	2	PTFE	#
14	Piston seal	1	NBR (*)	#
15	Integral piston	1	Carbon steel	
16	O-ring	1	NBR (*)	#
17	Internal sector ring	2	Carbon steel	
18	External sector ring	2	Carbon steel	
19	Rod	1	Alloy steel	
20	Plug	1	Carbon steel	
21	Integral head flange	1	Carbon steel	
22	Integral end flange	1	Carbon steel	
23	Spring cartridge tube	1	Carbon steel	
24	Relief valve	1	Stainless steel	
25	Screw	4	Carbon steel	
26	Screw	4	Carbon steel	

(*) NBR standard material for temperature range from -30°C up to +100°C.

10.3 Stop setting screw kit

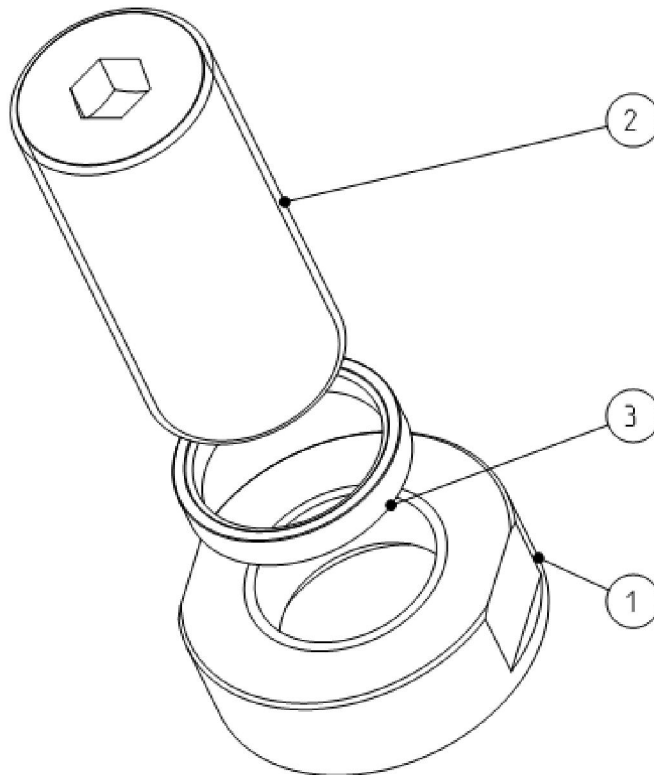

Stop setting screw kit part list

Item	Description	Qty	Material	Spare Parts
1	Nut	1	Stainless steel	
2	Stop screw	1	Stainless steel	
3	Seal washer	1	PTFE	#



11 SPARE PARTS

General references for the recommended spare parts are shown in the tables of Section 10.

Individual kit, including all the recommended spares, can be ordered directly to STI srl provided that serial number of the actuator or specific purchasing order for the original actuator is indicated in the request.

12 DECOMMISSIONING

Disposal and recycling

	<p>Warning: Before disassembling actuator it is necessary to intercept the hydraulic connection to discharge hydraulic cylinder and control unit o the atmosphere. If present discharge also the pressure from back-up tank.</p>
	<p>Warning: Refer to section 5.1 and section 5.4 to lifting and storage procedure</p> <p>Warning: If the actuator can be operated, put the actuator in fail safe position and unscrew totally the stopper screw with spring totally extended.</p> <p>Warning: The demolition of actuator parts should be made from specialized personnel.</p>

Before starting a large area should be created around the actuator so to allow any kind of movement without problems of further risks created by work site.

Subject	Hazardous	Recyclable	Disposal
Metals	No	Yes	Use licensed recyclers
Plastics	No	Yes	Use specialist recyclers
Rubber (seals and o-rings)	Yes	No	May require special treatment before disposal, use specialist waste disposal companies
Oil and grease	Yes	Yes	May require special treatment before disposal, use specialist waste disposal companies
Electric and Electronic equipment	Yes	Yes	Use specialist recyclers

	<p>Warning: Do not re-use parts or components which appear to be in good condition after they have been checked or replaced by qualified personnel and declared unsuitable for use.</p>
---	--

	<p>Important: In all cases check local authority regulation before disposal</p>
---	--

13 Declaration of Incorporation

	<p align="center">DICHIARAZIONE di INCORPORAZIONE (ai sensi dell'allegato II Sezione B della Direttiva Macchine 2006/42/CE)</p> <p align="center">DECLARATION of INCORPORATION (in accordance with EC Machinery Directive 2006/42/EC Annex II Section B)</p>
---	--

La Sottoscritta **STI S.r.l.** con sede in Via Dei Caravaggi, 15 – 24040 Levate (BG) – ITALIA dichiara, in qualità di costruttore sotto la propria responsabilità, che la quasi-macchina qui identificata:

We, STI S.r.l. based in Via Dei Caravaggi, 15 – 24040 Levate (BG) – ITALY, hereby declares, as the manufacturer under its sole responsibility, that the partly completed machinery here below identified:

Denominazione Generica: Attuatore Idraulico Quarto di Giro

Generic Denomination: Quarter Turn Hydraulic Actuator

Tipi/Types: RTCH; RTQH (Versione doppio effetto / Double acting version)

RTCHS; RTQHS (Versione singolo effetto / Single acting version)

- rispetta i seguenti RESS della Direttiva 2006/42/CE
complies with the following EHSRs of Directive 2006/42/EC:
1.1.1 - 1.1.2 - 1.1.3 - 1.1.5 - 1.2.1 - 1.2.2 - 1.3.1 - 1.3.2 - 1.3.4 - 1.3.7 - 1.3.8 - 1.4.1 - 1.5.1 - 1.5.2 - 1.5.3 - 1.5.4 - 1.5.5 - 1.5.6 - 1.5.7 - 1.5.13 - 1.6.1 - 1.7.1 - 1.7.2 - 1.7.3 - 1.7.4
- è destinata ad essere incorporata/assemblata in un'altra macchina, quasi-macchine o apparecchi.
is intended to be incorporated into a completed machinery or assembled with other partly completed machinery or equipment.
- non può essere messa in servizio prima che la macchina finale in cui sarà incorporata o con cui verrà assemblata sia stata dichiarata conforme alle disposizioni della direttiva 2006/42/CE.
must not be put into service until the final machinery into which it is to be incorporated has been declared in conformity with the provisions of Machinery Directive 2006/42/EC.
- è conforme alle seguenti Norme Armonizzate e altre Direttive, quando applicabili al materiale installato
complies with the following Standards and Directives, when applicable to the material installed:
 - Norma EN ISO 12100 (Ed.2010) / Standard EN ISO 12100 (Ed.2010)
 - Norma EN ISO 4413 (Ed.2010) / Standard EN ISO 4413 (Ed.2010)
 - Direttiva bassa tensione (DBT) 2014/35/UE / Low Voltage Directive (LVD) 2014/35/EU
 - Direttiva compatibilità elettromagnetica (EMC) 2014/30/UE
Electromagnetic Compatibility Directive (EMC) 2014/30/EU

La documentazione tecnica pertinente è stata compilata in conformità dell'allegato VII Sezione B: persona autorizzata alla costituzione: STI srl o/o STI srl Via Dei Caravaggi 15 – 24040 Levate (BG) Italia
The relevant technical documentation is compiled in accordance with the provisions of ANNEX VII Section B; person authorised to compile: STI srl at STI srl Via Dei Caravaggi 15 – 24040 Levate (BG) Italia.

Informazioni pertinenti riguardanti la quasi-macchina saranno trasmesse, in risposta ad una motivata richiesta, alle Autorità Nazionali. *The relevant information concerning the partly completed machinery will be transmitted, in response to a motivated request, to the National Authorities.*

Il modello, il numero di matricola, l'anno di costruzione, i dati del costruttore sono riportati sulla targa fissata alla quasi-macchina. *The model, serial number, year of manufacture, the manufacturer's data are shown on the nameplate attached to the partly completed machinery.*

Levate, 10 Gennaio 2018

L'Amministratore Delegato
Roberto Bertossi

IMI STI - Headquarters

Via Dei Caravaggi 15
24040 Levate (BG)
Italy

Tel. +39 035 2928.2
Fax +39 035 2928.247

IMI STI – Quarter Turn Division

Via San Francesco 18
29017 Fiorenzuola d'Arda (PC)
Italy

Tel. +39 035 2928.2
Fax +39 0523 1715.295

IMI Critical Engineering

Lakeside, Solihull Parkway
Birmingham Business Park
Birmingham B37 7XZ
United Kingdom

Tel. +44 (0)121 717 3700
Fax +44 (0)121 717 3701

www.stiactuation.com
www.imi-critical.com
imisti.sales@imi-critical.com