

# SC/Vo - METERING PUMP ACTUATOR

## INSTRUCTION MANUAL 5009



  
*Engineering  
GREAT Solutions*

*STI S.r.l. has taken every care in collecting and verifying the documentation contained in this Instruction Manual. The information herein contained are reserved property of STI S.r.l.*

## INDEX

<b>1</b>	<b>GENERAL INFORMATION.....</b>	<b>1</b>
1.1	GENERALITIES .....	1
1.2	MANUFACTURER .....	1
1.3	TERMS AND CONDITIONS .....	1
1.4	MANUFACTURER'S LIABILITY .....	1
1.5	APPLICABLE STANDARDS AND DIRECTIVES.....	2
1.6	SYMBOLGY USED .....	2
<b>2</b>	<b>DEVICE DESCRIPTION .....</b>	<b>3</b>
<b>3</b>	<b>TECHNICAL DATA .....</b>	<b>4</b>
<b>4</b>	<b>LABEL .....</b>	<b>5</b>
<b>5</b>	<b>OPERATING CONDITIONS AND INTENDED USE .....</b>	<b>6</b>
5.1	OPERATING CONDITIONS .....	6
5.2	INTENDED USE .....	6
<b>6</b>	<b>TRANSPORT .....</b>	<b>7</b>
<b>7</b>	<b>RECEPTION.....</b>	<b>7</b>
<b>8</b>	<b>STORAGE.....</b>	<b>7</b>
<b>9</b>	<b>INSTALLATION.....</b>	<b>8</b>
9.1	CHECKS TO BE PERFORMED BEFORE INSTALLATION.....	8
9.2	PNEUMATIC CONNECTIONS.....	8
9.3	EARTHLING CONNECTION .....	9
9.4	OIL CHARGE .....	9
<b>10</b>	<b>INSTRUCTION FOR THE OPERATORS.....</b>	<b>10</b>
10.1	FIELD ACTIVITIES .....	10
10.2	RESIDUAL RISKS .....	10
<b>11</b>	<b>MAINTENANCE.....</b>	<b>11</b>
11.1	PERIODIC INSPECTIONS AND MAINTENANCE.....	11
11.2	EXTRAORDINARY MAINTENANCE.....	11
11.3	GREASES .....	12
11.4	GASKETS REPLACEMENT .....	13
<b>12</b>	<b>PARTS LIST GENERAL ASSEMBLY .....</b>	<b>15</b>
<b>13</b>	<b>TROUBLESHOOTING .....</b>	<b>20</b>
<b>14</b>	<b>SPARE PARTS.....</b>	<b>20</b>
<b>15</b>	<b>DISASSEMBLING.....</b>	<b>21</b>
<b>16</b>	<b>DECOMMISSIONING.....</b>	<b>21</b>

# 1 GENERAL INFORMATION

<b>Important</b> 	<b>This Instruction Manual is an integral part of the machine, it should be carefully read before carrying out any operation and it should be kept for future references. The operators shall adopt the safety precautions required by the country where the product is installed. This Instruction Manual is realized in accordance with the Directive 2006/42/CE.</b>
---	---

## 1.1 Generalities

STI S.r.l. actuators are conceived, manufactured and controlled according to the Quality management System in compliance with EN ISO 9001 International Standard.

## 1.2 Manufacturer

With respect to Machinery Directive 2006/42/EC, the Manufacturer of the described SC/Vo actuator is STI S.r.l. as specified on the label.

STI S.r.l. Via Dei Caravaggi 15  
24040 Levate (BG) Italy  
Tel. +39 035 2928.2  
Fax +39 035 2928.247  
[imisti.sales@imi-critical.com](mailto:imisti.sales@imi-critical.com)

## 1.3 Terms and conditions

STI S.r.l. guarantees each single product to be free from defects and to conform to current goods specifications. The warranty period is two years from the date of shipment to the first user. The warranty does not cover special products or components not covered by warranty in their turn by subcontractors. No warranty is given for products which have been subject to improper storage, improper installation, improper maintenance or which have been modified or repaired by unauthorised personnel.

## 1.4 Manufacturer's liability

The SC/Vo actuator is designed in accordance with the applicable International Rules and Specifications, but the following regulations must be observed in any case:

- the general and safety regulations;
- the plant specific regulations and requirements;
- the proper use of personal devices, protective devices (glasses, clothing, gloves, etc), tools and transport equipment.

STI S.r.l. declines all liability in the event of:

- use SC/Vo actuator in other applications than the designated ones;
- use of the SC/Vo actuator in contravention of local safety at work legislation;
- lack of care during transport, installation, operations, maintenances of the SC/Vo actuator or incorrect application of the instructions provided on the SC/Vo actuator label and in this manual;
- modifications or repairs without STI S.r.l. authorisation;
- work done on the unit by unqualified or unsuitable operators.

Considering that STI S.r.l. has no direct control over particular applications, operation or maintenance conditions, it is the operator's responsibility to comply with all applicable safety rules; it is the sole responsibility of the operator to ensure that the local health and safety regulations are adhered to. Depending on the specific working conditions, additional precautions may be requested. Please inform STI S.r.l. urgently if you face unsafe situations not described in this Instruction Manual.

## 1.5 Applicable Standards and Directives

EN ISO 12100:2010	Safety of machinery - General principles for design – Risk assessment and risk reduction
IEC 61508:2010	Functional safety of electrical / electronic / programmable electronic safety-related systems
2006/42/EC	Machinery Directive
97/23/EC	Pressure Equipments Directive (PED)
94/9/CE	Equipments used in potentially explosive atmospheres (ATEX)

## 1.6 Symbology used

Dangerous symbols: be careful where these symbols are shown, they indicate a potentially hazardous situation and they warn that if the steps are not properly performed, may result causing serious injury, death or long-term risks to the health of exposed persons.



GENERAL DANGER



DANGER POWER SUPPLY



CRUSHING HAZARD

Obligation symbols: if these symbols are shown, the corresponding direction shall be followed.



General obligation (with the possible supplementary signboard)



Must wear protective clothing.



Must wear protective footwear.



Must wear protective helmet.



Must wear protective glasses



Must wear earplugs

## 2 DEVICE DESCRIPTION

The SC/Vo actuator is made by three main parts:

- *pneumatic cylinder* with double-acting piston, a part of which is full of oil;
- *oil tank*, which permits to have cylinder part always full of oil also when the piston is at the dead centre;
- the *manual override* (if required).

Different kind of pneumatic accessories could be mounting on the SC/Vo actuator depending on the performance required.



Figure 1 – SC/Vo metering pump actuator

### 3 TECHNICAL DATA

Model	Double Acting
	Casting Actuators
Cylinder material	Aluminum
Size (cylinder diameter) / Stroke	150mm / ≤40mm 200mm / ≤67mm - ≤100mm
Standard design pressure (*)	10bar
Standard operating temperature range (**)	-20°C/+70°C
Expected lifetime	20 years

(\*) For some special application the design pressure is 12 bar.

(\*\*) For some special application the operating temperature range could be another one included in the extended temperature range from -40°C to 100°C.

## 4 LABEL

Every SC/Vo actuator is provided with a label contains the main operating conditions and serial number. The label may change if the SC/Vo actuator is sold with reference to a Certificate of product and/or system issued by Notified Body Exterior or Certificate of Conformity issued by STI S.r.l..



 STI s.r.l. Via Dei Caravaggi 15 24040 LEVATE(Bg)-ITALY www.imi-critical.com - FAX +39 035 2928247			
MODELLO Model	<input type="text"/>	MATRICOLA Ident. No	<input type="text"/>
DN Size	<input type="text"/> mm	CORSA Stroke	<input type="text"/> mm
		ALIM.MAX Supply	<input type="text"/> bar
SEGNALE Signal	3 ÷ 15 psi <input type="checkbox"/>	0.2 ÷ 1 bar <input type="checkbox"/>	4 ÷ 20mA <input type="checkbox"/>
CAMPO SPECIALE Special range	<input type="text"/>	AZIONE Action	D. <input type="checkbox"/> R. <input type="checkbox"/> ON/OFF <input type="checkbox"/>
SIGLA Tag.No	<input type="text"/>		

Figure 2 – SC/Vo standard label

<b>Warning</b> 	<p><b>It is severely forbidden to use the SC/Vo actuator under conditions other than those provided on the label.</b></p>
---	---

<b>Important</b> 	<p><b>It is forbidden to modify the information and the marks without previous written authorization by STI S.r.l..</b></p> <p><b>Do not remove the label and/or replace with another label.</b></p>
---	--



## 5 OPERATING CONDITIONS AND INTENDED USE

<b>Warning</b> 	<p>It is severely forbidden to use the SC/Vo actuator for purpose or application other than those for which it was designed and here specified.</p>
---	---

### 5.1 Operating conditions

The label fastened on the SC/Vo actuator contains the main operating conditions for the specified application (see Section 4). Other operating conditions are reported on the documents accompanying the actuator. For general operating conditions see Section 3.

### 5.2 Intended use

The SC/Vo actuator series has been specifically designed for metering pumps. In order to open/close the pump without the support of the supply fluid, in some application the manual override is required. Every manual override is provided with a label contains the correct using steps.

**STI s.r.l. Via Dei Caravaggi 15 24040 LEVATE(Bg)-ITALY**  
**www.imi-critical.com - FAX +39 035 2928247**

**CONNECTION OF THE HANDWHEEL CONTROL**  
**Inserimento comando manuale**

- 1) Turn the handwheel clockwise to the stop ring splined to the cylinder shaft  
 Girare il volantino in senso orario fino a raggiungere l'anello di fermo calettato sullo stelo del cilindro
- 2) Insert the pin in the hole  
 Inserire la spina nell'apposito foro
- 3) Open the by pass valve  
Aprire la valvola di by-pass
- 4) Do not force the handwheel beyond the limits of the stroke  
 Non forzare il comando manuale oltre i limiti di fine corsa

Figure 3 – Manual override standard label

After the manual override using, take off the manual override pin and then check the correct behavior of the SC/Vo actuator with a functional test or a visual check of the pin.

## 6 TRANSPORT

<p><b>Warning</b></p> 	<p>The following instructions must be respected:</p> <ul style="list-style-type: none"> <li>- operations must be carried out only by skilled operators;</li> <li>- always wear protective clothing, gloves, and eyewear to prevent personal injury. Check with your process or safety engineer for any additional measures that must be taken to protect against process media.</li> </ul>
---	--

<p><b>Important</b></p> 	<p>The lifting and handling should be made in compliance with the laws and provisions in force.</p>
---	---

Lift the SC/Vo actuator with belts, using its eyebolts. Make sure that the belts never scratches the accessories and pneumatic/electric connection.

## 7 RECEPTION

SC/V actuator leave the factory in perfect condition. Performances of each unit are guaranteed by tests and data reported on a specific Test Report. At the reception of the SC/V actuator:

- check that the model correspond with that of order confirmation;
- check that the pneumatic diagrams, wiring diagrams and dimensional drawing are furnished with document accompanying the actuator;
- check that the SC/Vo actuator was not damaged during transportation. If necessary, renovate the painting according to the specification reported on the order confirmation.

## 8 STORAGE

In order to maintain the guaranteed actuator performances until the SC/Vo actuator is installed on site, proper attention must be observed for preservation during the storage period. If the SC/Vo actuator needs storage before installation:

- place it in a dry, clean place and take all necessary measures to avoid contact with dust, dirt and humidity during storage;
- make sure that connection protections and/or the mechanical locks will not be removed during the storage;
- storage temperature must be between -20°C and +40°C.

## 9 INSTALLATION

<b>Warning</b> 	<p>The following instructions must be respected:</p> <ul style="list-style-type: none"> <li>- operations must be carried out only by skilled operators;</li> <li>- always wear protective clothing, gloves, and eyewear to prevent personal injury. Check with your process or safety engineer for any additional measures that must be taken to protect against process media.</li> </ul>
---	--

<b>Important</b> 	<p>Not performing the following procedures will invalidate the product warranty.</p>
---	--

### 9.1 Checks to be performed before installation

It is recommended to check the SC/Vo actuator conditions before the installation, then:

- prepare the necessary tools for the assembly and setting of the unit;
- check that the coupling dimensions meet the specified coupling dimensions;
- clean the SC/Vo actuator surfaces and remove anything that might prevent a perfect adherence.

<b>Warning</b> 	<p>Do not lift the pump with the SC/Vo actuator eyebolts.</p>
---	---

### 9.2 Pneumatic connections

<b>Warning</b> 	<p>Check that the values of pneumatic supply available are compatible with those reported on the label of the SC/Vo actuator: a pressure regulator is absolutely necessary when supply pressure is higher than max operating pressure. User must consider and take all precautions to avoid that pressurized parts are not used out of specified range and to avoid exposure to fire.</p>
---	---

<b>Important</b> 	<p>For easier maintenance, it is recommended to install a filter with five micron cartridge and shut-off valve on the supply connection.</p>
---	--

It is required to follow these steps during the pneumatic connection:

- no lubricators on supply fluid line is required;
- use pipes and connections appropriate as for type, rating, material and dimensions;
- properly deburr the ends of rigid pipes;
- properly clean the interior of pipes sending through them plenty of the supply fluid;
- use pipe sealant sparingly and only on male threads. A non-hardening sealant is strongly recommended;
- fasten the connection pipes so that no irregular strains or loosening of threaded connections occur;

- make the pneumatic connections according to the pneumatic diagram;
- check the absence of leakages from pneumatic connections. If necessary, tighten the nuts of the pipe-fittings;
- after connecting the actuator, gradually increase the supply pressure up to the maximum operating pressure.

### 9.3 Earthing connection

<p><b>Warning</b></p> 	<p><b>Check if the SC/Vo actuator has a properly earthing connection.</b></p>
---	---

The earthing connection is guaranteed through the fixing flange of the SC/Vo actuator. If the earthing connection of the system where SC/Vo actuator is mounted is not guaranteed, it is required to ensure a directly earthing connection.

### 9.4 Oil charge

The first oil charge must be effected as follows:

1. remove the oil reservoir from the actuator taking off the fixing screw;
2. effect the filling with ESSO NUTO oil (heated at 50°C) making slow alternated piston movements in order to bleed the air. Filling is completed when the piston is at the lower dead centre and the upper cylinder chamber is completely full of oil.
3. Reassemble oil tank and pour the oil through the cap until the maximum level shown on level rod is reached.
4. Connect pneumatic connections and after having checked the seals, put actuator in service, performing some alternated strokes with slow movements in order to bleed the cylinder.

## 10 INSTRUCTION FOR THE OPERATORS

<b>Warning</b> 	<p>The following instructions must be respected:</p> <ul style="list-style-type: none"> <li>- operations must be carried out only by skilled operators;</li> <li>- always wear protective clothing, gloves, and eyewear to prevent personal injury. Check with your process or safety engineer for any additional measures that must be taken to protect against process media.</li> </ul>
---	--

<b>Important</b> 	<p>Any repair work other than the operations outlines in this Instruction Manual is allowed only if STI S.r.l. authorises it.</p>
---	---

### 10.1 Field activities

During the start-up of the SC/Vo actuator:

- check that the pressure and quality of the supply fluid (filtering degree, dehydration, etcetera) are as prescribed;
- check if the operating condition are as prescribed;
- check if the actuator is perfectly aligned with the pump stem;
- check that there are no leaks of the pneumatic connections;
- check that there are no leaks of the accessories mounted on the SC/Vo actuator;
- check that there are no leaks of the cylinder of SC/Vo actuator;
- remove all rust on the SC/Vo actuator surfaces;
- repair paint-coat that has been damaged, in accordance with the applicable painting specifications;
- perform a complete functional test.

### 10.2 Residual Risks

Reasonably foreseeable misuse:

- risk due to movements of loads during transport and installation;
- crushing during transport and installation;
- installation in ambient with not planned conditions;
- metal temperature at high or very low values as consequence of ambient temperature as to be considered as a risk of person injury in case of contact;
- insert incorrect motive fluid into the system;
- supply pressure out of planned range;
- emissions of hazardous substances where dangerous gases are used as motive fluid.

## 11 MAINTENANCE

<p><b>Warning</b></p> 	<p><b>The following instructions must be respected:</b></p> <ul style="list-style-type: none"> <li>- operations must be carried out only by skilled operators (STI operators or operators qualified by STI are recommended);</li> <li>- always wear protective clothing, gloves, and eyewear to prevent personal injury. Check with your process or safety engineer for any additional measures that must be taken to protect against process media.</li> </ul>
---	---

Before any type of operation and/or maintenance is performed, make sure that:

- actuator, accessories and all connected equipment are not under pressure and in safe conditions;
- fluid supply, power or other energy sources and signals are disconnected;
- actuator is free from any mechanism able to move.

### 11.1 Periodic Inspections and maintenance

Periodic visual inspections are recommended. The user shall:

- plan and provide for a periodic cleaning/maintenance program that will maintain the external surface of the SC/Vo actuator free from excessive layer of dust.
- Lubrication the external mechanical devices in motion every six months (see Section 11.3 for the correct grease type).
- Check painting status of the entire actuator at least every three months. If any damage on the painting film is present, the user shall immediately carry out an adequate painting touch-up.
- Replace the gaskets and the grease every 2-3 years depending on the actuator operating conditions.
- Check oil level every three working months. In this case it is necessary:
  - o to carry the piston to the top dead centre.
  - o Check that oil level into the tank is as stated on the measuring stick insert in the tank and eventually add the necessary quantity.
  - o Added oil must be free from impurities that might damage the hydraulic resistance mounted on the circuit.

### 11.2 Extraordinary maintenance

In case of extraordinary maintenance, following malfunction and related troubleshooting, proceed as written in Section 13.

### 11.3 Greases

SC/Vo cylinder material	Very Low temperature (Tmin ≤ -40°C)	Low temperature (-40°C < Tmin < -20°C)	Standard temperature (-20°C ≤ T ≤ -70°C)	High temperature (Tmax > 70°C)
Aluminum	RHEOLUBE 361F (Tecnolube seal)	RHOESIL 500F (Tecnolube seal)	MOLYGUARD IDROSFER	SYNTHY 101 (Tecnolube seal)
Nickel plated carbon steel	RHEOLUBE 361F (Tecnolube seal)	RHOESIL 500F (Tecnolube seal)	MOLYGUARD IDROSFER	SYNTHY 101 (Tecnolube seal)
Chrome plated carbon steel	RHEOLUBE 361F (Tecnolube seal)	RHOESIL 500F (Tecnolube seal)	POLIMER 400/1 (Tecnolube seal)	SYNTHY 101 (Tecnolube seal)
Stainless steel	RHEOLUBE 361F (Tecnolube seal)	RHOESIL 500F (Tecnolube seal)	POLIMER 400/1 (Tecnolube seal)	SYNTHY 101 (Tecnolube seal)
Fiber	RHEOLUBE 361F (Tecnolube seal)	RHOESIL 500F (Tecnolube seal)	POLIMER 400/1 (Tecnolube seal)	SYNTHY 101 (Tecnolube seal)

Manual override material	Very Low temperature (Tmin ≤ -40°C)	Low temperature (-40°C < Tmin < -20°C)	Standard temperature	High temperature (Tmax > 70°C)
All material	MOLIKOTE	MU EP (Agip)	MU EP (Agip)	MU EP (Agip)

## 11.4 Gaskets replacement

### Warning



The following instructions must be respected:

- operations must be carried out only by qualified staff (STI operators or operators qualified by STI are recommended);
- always wear protective clothing, gloves, and eyewear to prevent personal injury. Check with your process or safety engineer for any additional measures that must be taken to protect against process media.

During gaskets replacement, for both size 150mm and 200mm:

- take care to not damage gaskets grooves during maintenance;
- use only the grease type shown in the enclosed table.

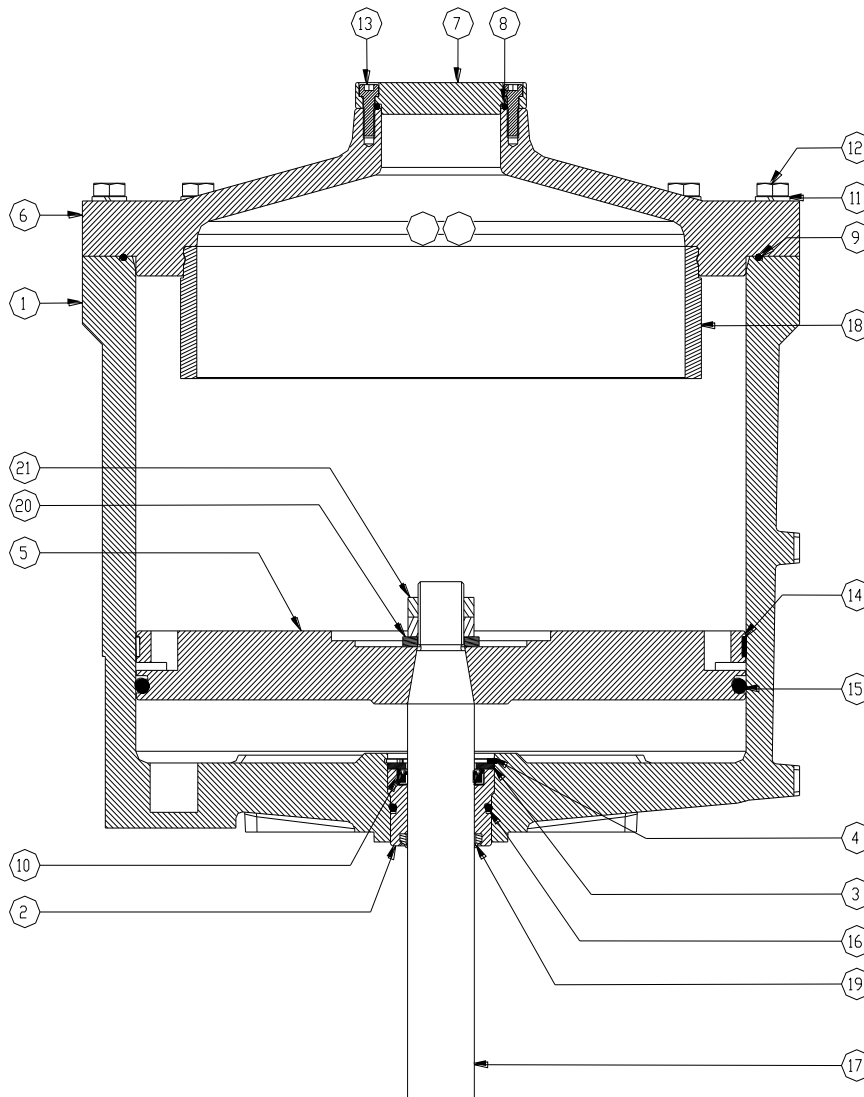

### Disassembling:

- 9.1 Disconnect the actuator from the air supply and ensure the actuator is not pressurized.
- 9.2 Disconnect the actuator stem from the pump stem.
- 9.3 Disassemble the upper actuator cover by removing the screws (pos.12) and all the accessories / fittings where needed.
- 9.4 Remove the shaft (pos.17) and piston (pos.5) from the cylinder (pos.1).
- 9.5 Remove o-ring (pos. 9) from the cylinder.
- 9.6 Remove the sliding ring (pos. 14) and o-ring (pos.15) from the piston.



- 9.7 Remove snap ring (pos.4). Push the bushing (pos.2) towards the inside of the actuator and remove the gaskets (pos.3,10 and 19).
- 9.8 For stroke lengths of less than 100 mm (top mounting positioner):
  - 9.8.1 remove screws (pos.24);
  - 9.8.2 remove the positioner and its linkage and remove the flange;
  - 9.8.3 replace the wiper ring (pos.22) and o-rings (pos.25 e 23).

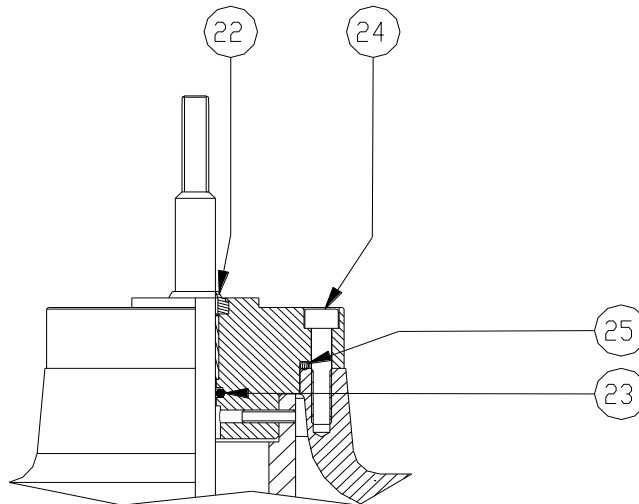

**Replacement:**

- 9.9 Clean the actuator parts with a mild detergent suitable for grease using a brush, then dry with a cloth and compressed air.
- 9.10 Apply grease on the rough parts of the bottom of the cylinder. Do not apply grease of the machined surfaces on the bottom of the cylinder.
- 9.11 Apply grease to the o-rings and install them on the bushings. Insert and fix the bushing into the cylinder.
- 9.12 Fill the grease reservoir along the outer rim of the piston.

**Important**



**Apply grease to gaskets prior installation.**

- 9.13 Install new gaskets kit.
- 9.14 Apply grease to the inside surface of the cylinder.
- 9.15 Install the sliding ring on the piston.
- 9.16 Install the o-ring on the piston and remove the excess grease.
- 9.17 Insert the piston into the cylinder.
- 9.18 Mount the upper cover on the actuator. Torque the nuts to the value indicated into the table below.
- 9.19 Test the piston movement using an air gun.
- 9.20 Plumb all pneumatic connections and check for air leaks at 1 bar (0,1 MPa) air supply pressure. If there are no leaks, repeat the test at 7 bar (0,7 MPa).
- 9.21 Remove the excess grease from the shaft.

Size	Torque [Nm]
150	10 (7,4 lbf-ft)
200	14 (10,3 lbf-ft)

## 12 PARTS LIST GENERAL ASSEMBLY

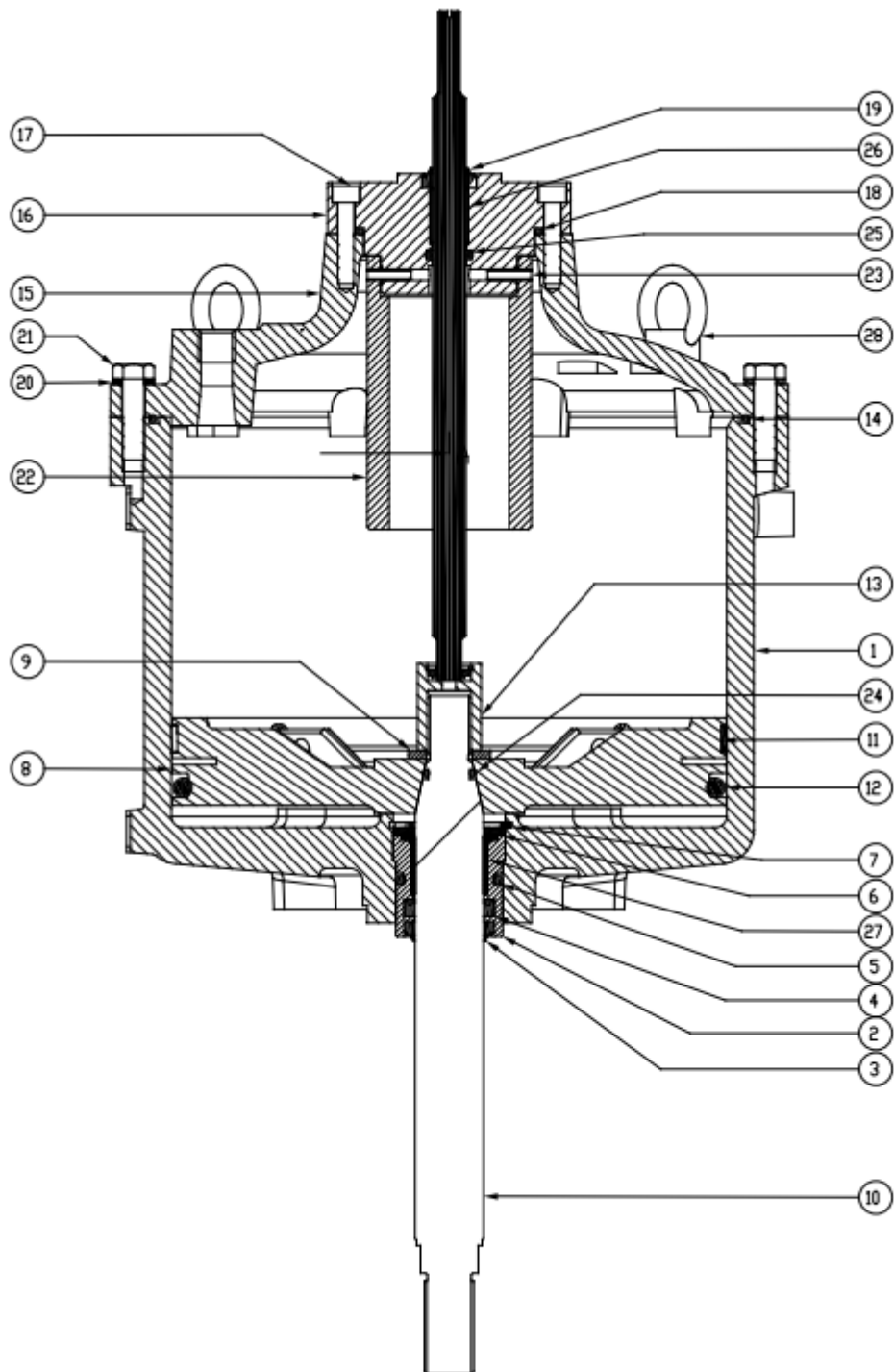

Figure 4 – Casting Actuator: typical design

PDS.	DESCRIZIONE
1	CYLINDER BODY
2	BUSHING
3	DUST SEAL GASKET
4	DUST COVER
5	SEALING RING
6	PROTECTION WASHER
7	STOP RING
8	PISTON
9	FLAT WASHER
10	STELD
11	SLYD RING PISTON
12	SEALING RING PRP
13	STEM CONTROL LEVER
14	SEALING RING PRP
15	UPPER COVER
16	COUPLING FLANGE
17	SCREW TCEI
18	SEALING RING
19	DUST SEAL GASKET
20	LOCK WASHER
21	SCREW TE
22	STROKE LIMITATOR
23	ELASTIC PIN
24	SEALING RING DR 3056
25	SEALING RING DR 115
26	BEARING GLY.PG
27	BEARING GLYCODUR
28	EYEBOLT

Figure 5 – Casting Actuator: typical design

POS.	DESCRIPTION
3	BUSHING
4	GASKET
5	DUST SEAL GASKET
6	PROTECTION WASHER
15	STEM
18	SEALING RING
23	STOP RING
28	BEARING BUSHING

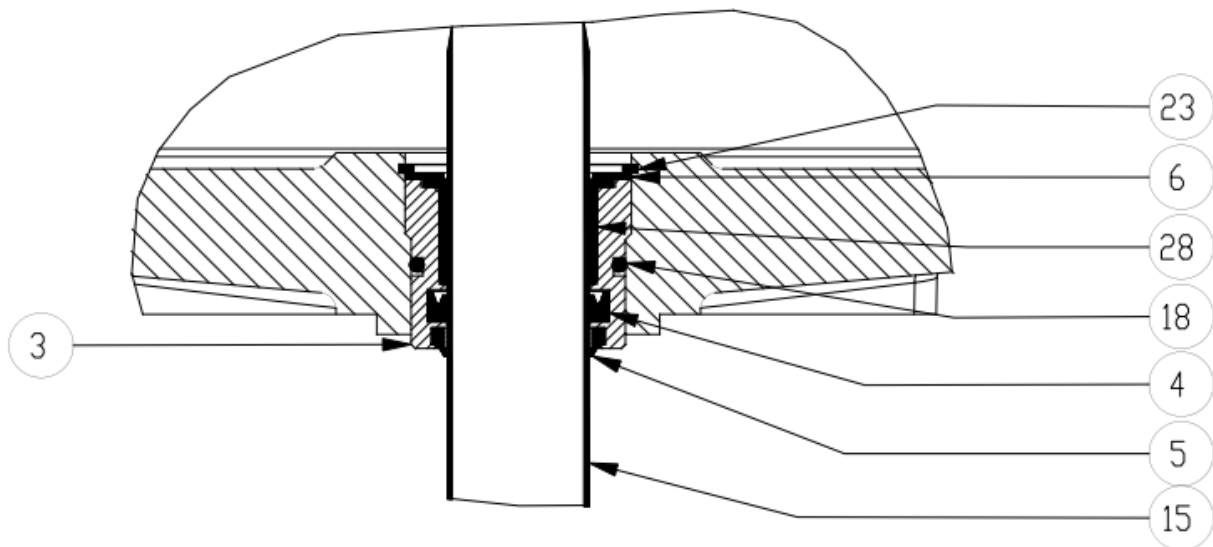

Figure 6 – Casting Actuator: option A

POS.	DESCRIPTION
7	PISTON
9	FLAT WASHER
11	COUPLING FLANGE
13	KNURLED WASHER SCHONDR
14	SCREW TCEI
15	STEM
27	SEALING RING OR 3243
29	STEM CONTROL LEVER
30	SEALING RING OR 115
31	BEARING GLYPG 121420 F
32	DUST SEAL GASKET ASDB 12-4

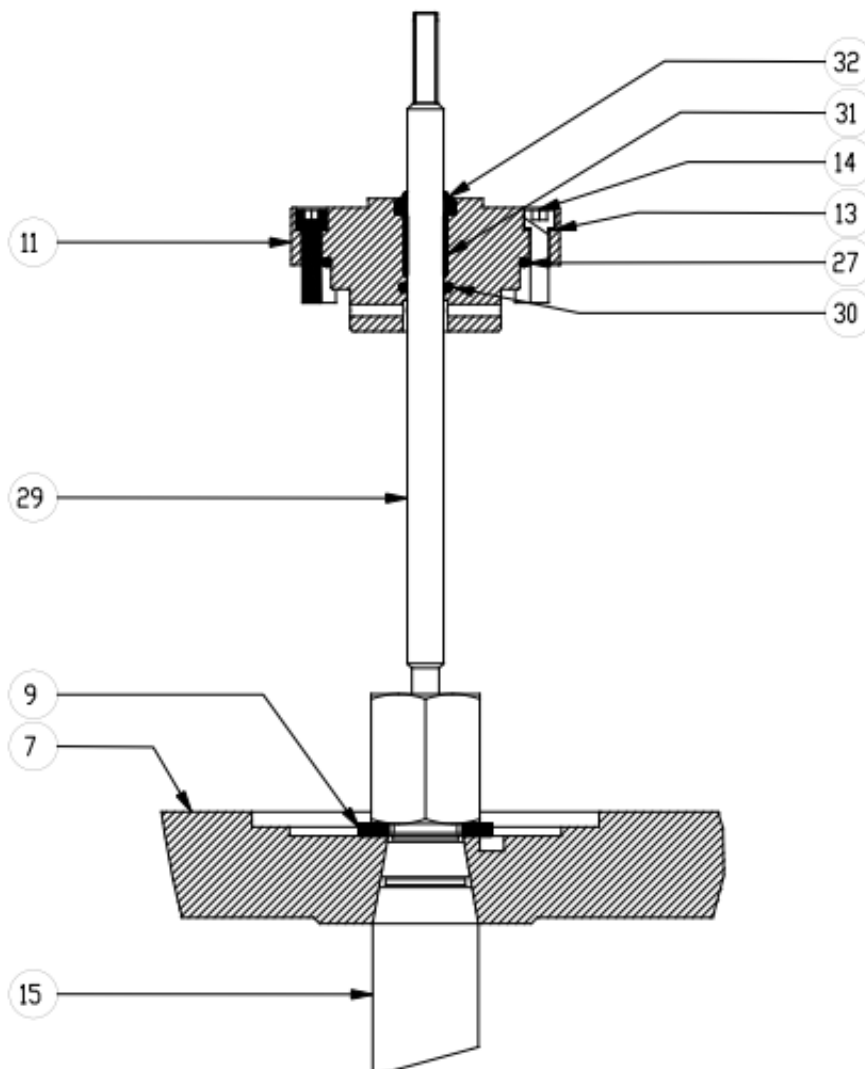
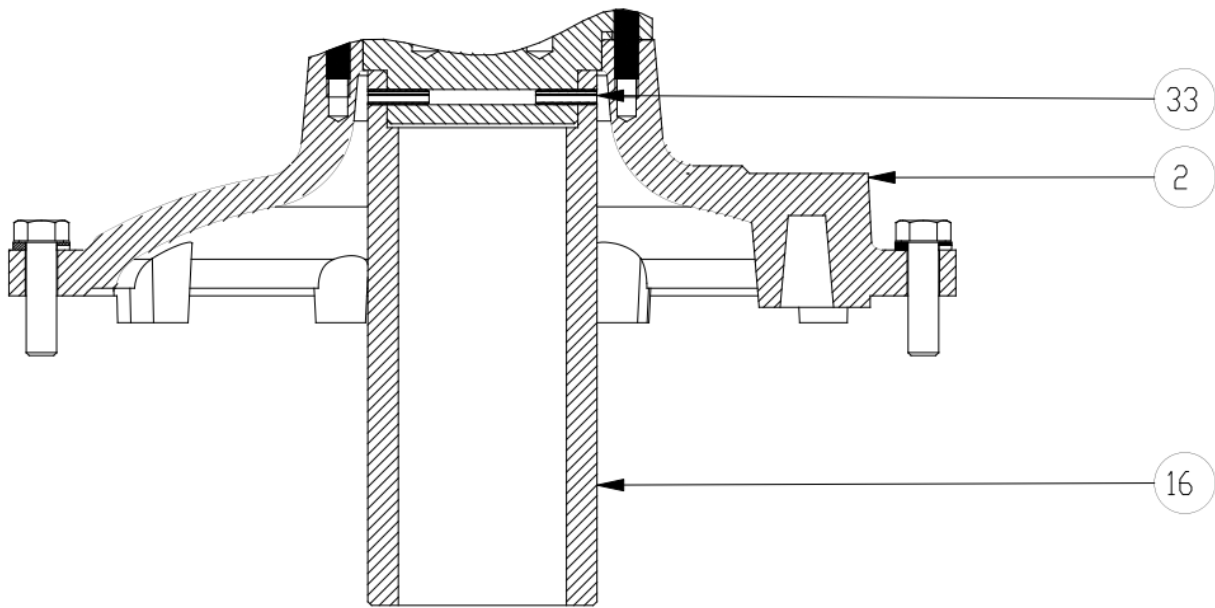

Figure 7 – Casting Actuator: option B



PDS.	DESCRIPTION
2	UPPER COVER
16	STROKE LIMITATOR
33	ELASTIC PIN

Figure 8 – Casting Actuator: option C

PDS.	DESCRIPTION
2	COVER
16	STROKE LIMITATOR
34	SCREW

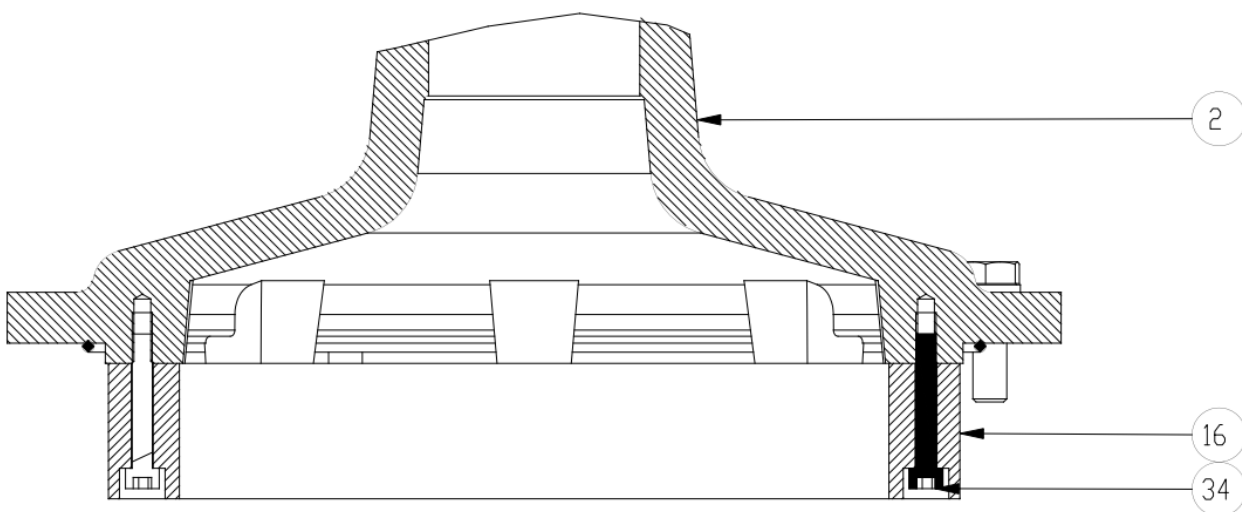

Figure 9 – Casting Actuator: option D

## 13 TROUBLESHOOTING

EVENT	POSSIBLE CAUSE	REMEDY
SC/Vo actuator doesn't move	Lack of pneumatic supply	Check supply line
	Low supply pressure	Adjust supply pressure
	Pneumatic circuit failure	Call STI S.r.l.
	Thrust on stem not enough (metering pump seizing)	Call metering pump manufacturer
	Thrust on stem not enough (wrong actuator sizing)	Call STI S.r.l.
	Presence of an external obstruction	Put the SC/Vo actuator in a safety condition and remove the obstruction
	Damaged actuator internal component	Call STI S.r.l.
SC/Vo actuator doesn't move in a linear way	Lubricators unsuitable	Replace the lubricators
		Call STI S.r.l.
	Stem misalignment	Check the actuator stem alignment
		Call STI S.r.l.
Thrust on stem not enough (metering pump seizing)	Call metering pump manufacturer	
Thrust on stem not enough (wrong actuator sizing)	Call STI S.r.l.	
Opening/Closing time not satisfy	Incorrect positioner calibration	Call STI S.r.l.
	Pneumatic circuit not suitable	Call STI S.r.l.
	Wrong actuator sizing	Call STI S.r.l.
Leakages from pneumatic cylinder	Deterioration and/or damage of gasket	Replace the gaskets
		Call STI S.r.l.
	Deterioration and/or damage of the cylinder or the upper/lower cap	Call STI S.r.l.
Incorrect tie rods tighten	Call STI S.r.l.	
Leakages from pneumatic circuit	The nuts of pipe fittings are not tightened enough	Tighten the nuts
	An accessory does not work correctly	Call STI S.r.l.

### Important



**If another event happens or another possible cause of the above events has been detected, call STI S.r.l.**

## 14 SPARE PARTS

Contact STI S.r.l. for the gasket kit required for gaskets replacement. Other spare parts can be sent to the customer if required.

## 15 DISASSEMBLING

<p><b>Important</b></p> 	<p>The customer can disassemble the SC/Vo actuator only for the gaskets/grease replacement (see Section 11). In other cases, the disassembling is not allowed if it is not authorized by STI.</p>
---	---

## 16 DECOMMISSIONING

<p><b>Warning</b></p> 	<p>The following instructions must be respected:</p> <ul style="list-style-type: none"> <li>- operations must be carried out only by skilled operators;</li> <li>- always wear protective clothing, gloves, and eyewear to prevent personal injury. Check with your process or safety engineer for any additional measures that must be taken to protect against process media.</li> </ul>
---	--

<p><b>Important</b></p> 	<p>Check local authority regulation before disposal.</p>
--	--

SUBJECT	HAZARDOUS	RECYCABLE	DISPOSAL
Metals	No	Yes	Use licensed recyclers
Plastics	No	Yes	Use specialist recyclers
Rubber (seals, o-rings)	Yes	No	May require special treatment before disposal, use specialist waste disposal companies
Oil and grease	Yes	Yes	May require special treatment before disposal, use specialist waste disposal companies



**IMI STI - Headquarters**

Via Dei Caravaggi 15  
24040 Levate (BG)  
Italy

Tel. +39 035 2928.2  
Fax +39 035 2928.247

**IMI STI - Sales Office**

Via San Francesco 18  
29017 Fiorenzuola d'Arda (PC)  
Italy

Tel. +39 035 2928.2  
Fax +39 0523 1715.295

**IMI Critical Engineering**

Lakeside, Solihull Parkway  
Birmingham Business Park  
Birmingham B37 7XZ  
United Kingdom

Tel. +44 (0)121 717 3700  
Fax +44 (0)121 717 3701

[www.stiactuation.com](http://www.stiactuation.com)  
[www.imi-critical.com](http://www.imi-critical.com)  
[imisti.sales@imi-critical.com](mailto:imisti.sales@imi-critical.com)