

SC/MH



Engineering
GREAT Solutions

Hydraulic Linear Actuator

SC/MH: Hydraulic Linear Actuator

IMI STI's hydraulic linear piston actuators are designed to drive on/off and control valves for the most demanding applications in the Power and Oil & Gas industries; such as choke, gate, globe and wedge valves.

Thanks to the rugged and reliable design SC/MH actuators ensure smooth and precise valve operation without any maintenance for the whole operating life, even in the harshest of environments.

Key features

- > Several sizes available from 30mm to 300 mm or larger if required
- > Several stroke options available
- > Double acting or spring return design
- > Manufactured in carbon steel material without any cast/grey/ductile iron or aluminium parts
- > Full stainless steel design available for both double acting and spring return actuators
- > Action inversion without tubing inversion only for ND 1/4" version
- > Electroless nickel plated cylinder to minimise friction and prevent corrosion
- > Multiple lifting lugs ideally located to balance centre of gravity for safe lifting
- > An integral or declutchable manual hand-wheel or hydraulic hand pump available on request
- > Customised valve bracket, open or close design on request
- > Quick connection solution for valve adaptation available on request



Safe, strong, reliable and compact

Benefits

- > **Safe**
Maximum safety is ensured by the design of spring packs as spring compression is independent from removal of cylinder cap and tie rods
- > **Strong**
The compact design means the actuator is not sensitive to vibration and external loads
- > **Reliable**
Double guide for piston, bushing and heavy-duty nickel plated cylinder ensure safe and reliable operation
- > **Compact**
Designed to provide high performance with minimum space and weight



Manual override available

Technical specifications

Operating pressure

Up to 350 barg

Certifications and approvals

PED 2014/68/EU

ATEX 2014/34/EU

MACHINERY DIRECTIVE 2006/42/EC

IP66/67M according to IEC/EN 60529

Standard operating temperature

-30 °C to +100°C (lower or higher temperature on request)

Standard supply medium

Hydraulic oil

Fire resistant fluid version on request



General view inside HPU

Product breakdown

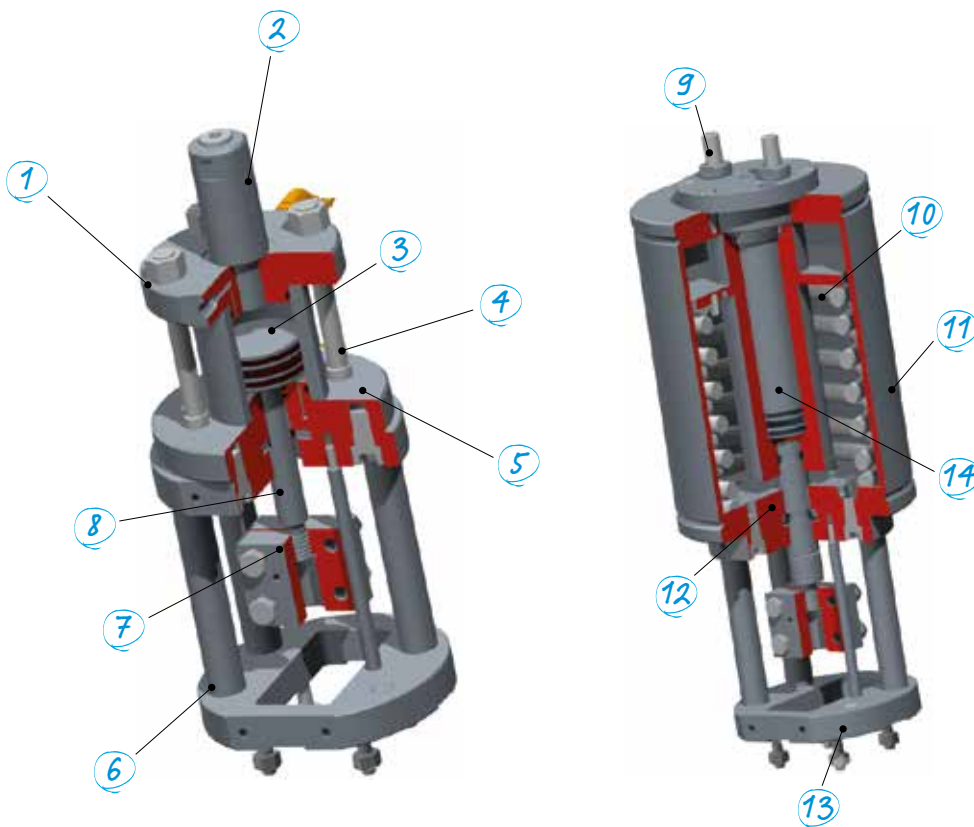

1. End flange
2. Stopper protection
3. Piston
4. Tie rod
5. Head flange
6. Bracket
7. Stem adaptor
8. Cylinder stem
9. Stop screw
10. Spring
11. Spring container
12. Scraper
13. Stud bolt
14. Piston gasket

Optional accessories

IMI STI designs and produces a wide range of accessories and control systems to ensure superior performance and to satisfy the most demanding requirements in modulating, on/off and heavy duty service. Control systems panels/cabinets can be installed on the actuators or supplied separately for remote mounting which allows for easy access and to limit exposure to excess heat and vibration. For more information, see our dedicated accessories brochure or visit www.imi-critical.com.

IMI STI - Headquarters

Via Dei Caravaggi 15
24040 Levate (BG)
Italy

Tel. +39 035 2928.2
Fax +39 035 2928.247

IMI STI - Quarter Turn Division

Via San Francesco 18
29017 Fiorenzuola d'Arda (PC)
Italy

Tel. +39 035 2928.2
Fax +39 0523 1715.295

IMI Critical Engineering

Lakeside, Solihull Parkway
Birmingham Business Park
Birmingham B37 7XZ
United Kingdom

Tel: +44 (0)121 717 3700
Fax: +44 (0)121 717 3701

www.imi-critical.com
imisti.sales@imi-critical.com

